

# —INTERNATIONAL—

## Lights and Shapes

### **PART C—LIGHTS AND SHAPES**

#### **RULE 20**

##### **Application**

- (a) Rules in this Part shall be complied with in all weathers.
- (b) The Rules concerning lights shall be complied with from sunset to sunrise, and during such times no other lights shall be exhibited, except such lights as cannot be mistaken for the lights specified in these Rules or do not impair their visibility or distinctive character, or interfere with the keeping of a proper look-out.
- (c) The lights prescribed by these Rules shall, if carried, also be exhibited from sunrise to sunset in restricted visibility and may be exhibited in all other circumstances when it is deemed necessary.
- (d) The Rules concerning shapes shall be complied with by day.
- (e) The lights and shapes specified in these Rules shall comply with the provisions of Annex I to these Regulations.

—INLAND—  
Lights and Shapes

**PART C—LIGHTS AND SHAPES**

**RULE 20**

**Application**

- (a) Rules in this Part shall be complied with in all weathers.
- (b) The Rules concerning lights shall be complied with from sunset to sunrise, and during such times no other lights shall be exhibited, except such lights as cannot be mistaken for the lights specified in these Rules or do not impair their visibility or distinctive character, or interfere with the keeping of a proper look-out.
- (c) The lights prescribed by these Rules shall, if carried, also be exhibited from sunrise to sunset in restricted visibility and may be exhibited in all other circumstances when it is deemed necessary.
- (d) The Rules concerning shapes shall be complied with by day.
- (e) The lights and shapes specified in these Rules shall comply with the provisions of Annex I of these Rules.

# —INTERNATIONAL—

## Lights and Shapes

### **RULE 21**

#### **Definitions**

(a) “Masthead light” means a white light placed over the fore and aft centerline of the vessel showing an unbroken light over an arc of the horizon of 225 degrees and so fixed as to show the light from right ahead to 22.5 degrees abaft the beam on either side of the vessel.

(b) “Sidelights” means a green light on the starboard side and a red light on the port side each showing an unbroken light over an arc of the horizon of 112.5 degrees and so fixed as to show the light from right ahead to 22.5 degrees abaft the beam on its respective side. In a vessel of less than 20 meters in length the sidelights may be combined in one lantern carried on the fore and aft centerline of the vessel.

(c) “Sternlight” means a white light placed as nearly as practicable at the stern showing an unbroken light over an arc of the horizon of 135 degrees and so fixed as to show the light 67.5 degrees from right aft on each side of the vessel.

(d) “Towing light” means a yellow light having the same characteristics as the “sternlight” defined in paragraph (c) of this Rule.

(e) “All-round light” means a light showing an unbroken light over an arc of the horizon of 360 degrees.

(f) “Flashing light” means a light flashing at regular intervals at a frequency of 120 flashes or more per minute.

# —INLAND—

## Lights and Shapes

### **RULE 21**

#### **Definitions**

(a) “Masthead light” means a white light placed over the fore and aft centerline of the vessel showing an unbroken light over an arc of the horizon of 225 degrees and so fixed as to show the light from right ahead to 22.5 degrees abaft the beam on either side of the vessel, except that on a vessel of less than 12 meters in length the masthead light shall be placed as nearly as practicable to the fore and aft centerline of the vessel.

(b) “Sidelights” mean a green light on the starboard side and a red light on the port side each showing an unbroken light over an arc of the horizon of 112.5 degrees and so fixed as to show the light from right ahead to 22.5 degrees abaft the beam on its respective side. On a vessel of less than 20 meters in length the sidelights may be combined in one lantern carried on the fore and aft centerline of the vessel, except that on a vessel of less than 12 meters in length the sidelights when combined in one lantern shall be placed as nearly as practicable to the fore and aft centerline of the vessel.

(c) “Sternlight” means a white light placed as nearly as practicable at the stern showing an unbroken light over an arc of the horizon of 135 degrees and so fixed as to show the light 67.5 degrees from right aft on each side of the vessel.

(d) “Towing light” means a yellow light having the same characteristics as the “sternlight” defined in paragraph (c) of this Rule.

(e) “All-round light” means a light showing an unbroken light over an arc of the horizon of 360 degrees.

(f) “Flashing light” means a light flashing at regular intervals at a frequency of 120 flashes or more per minute.

(g) “Special flashing light” means a yellow light flashing at regular intervals at a frequency of 50 to 70 flashes per minute, placed as far forward and as nearly as practicable on the fore and aft centerline of the tow and showing an unbroken light over an arc of the horizon of not less than 180 degrees nor more than 225 degrees and so fixed as to show the light from right ahead to abeam and no more than 22.5 degrees abaft the beam on either side of the vessel.

# —INTERNATIONAL—

## Lights and Shapes

### **RULE 22**

#### **Visibility of Lights**

The lights prescribed in these Rules shall have an intensity as specified in Section 8 of Annex I to these Regulations so as to be visible at the following minimum ranges:

(a) In vessels of 50 meters or more in length:

- a masthead light, 6 miles;
- a sidelight, 3 miles;
- a sternlight, 3 miles;
- a towing light, 3 miles;
- a white, red, green or yellow all-round light, 3 miles.

(b) In vessels of 12 meters or more in length but less than 50 meters in length:

- a masthead light, 5 miles; except that where the length of the vessel is less than 20 meters, 3 miles;
- a sidelight, 2 miles;
- a sternlight, 2 miles;
- a towing light, 2 miles;
- a white, red, green or yellow all-round light, 2 miles.

(c) In vessels of less than 12 meters in length:

- a masthead light, 2 miles;
- a sidelight, 1 mile;
- a sternlight, 2 miles;
- a towing light, 2 miles;
- a white, red, green or yellow all-round light, 2 miles.

(d) In inconspicuous, partly submerged vessels or objects being towed:

- (a) a white all-round light, 3 miles.

# —INLAND—

## Lights and Shapes

### **RULE 22**

#### **Visibility of Lights**

The lights prescribed in these Rules shall have an intensity as specified in Annex I to these Rules, so as to be visible at the following minimum ranges:

(a) In a vessel of 50 meters or more in length:

- a masthead light, 6 miles;
- a sidelight, 3 miles;
- a sternlight, 3 miles;
- a towing light, 3 miles;
- a white, red, green or yellow all-round light, 3 miles; and
- a special flashing light, 2 miles.

(b) In a vessel of 12 meters or more in length but less than 50 meters in length:

- a masthead light, 5 miles; except that where the length of the vessel is less than 20 meters, 3 miles;
- a sidelight, 2 miles;
- a sternlight, 2 miles;
- a towing light, 2 miles;
- a white, red, green or yellow all-round light, 2 miles; and
- a special flashing light, 2 miles.

(c) In a vessel of less than 12 meters in length:

- a masthead light, 2 miles;
- a sidelight, 1 mile;
- a sternlight, 2 miles;
- a towing light, 2 miles;
- a white, red, green or yellow all-round light, 2 miles; and
- a special flashing light, 2 miles.

(d) In an inconspicuous, partly submerged vessel or object being towed:

- a white all-round light, 3 miles.

# —INTERNATIONAL—

## Lights and Shapes

### RULE 23

#### Power-driven Vessels Underway

- (a) A power-driven vessel underway shall exhibit:
- (i) a masthead light forward;
  - (ii) a second masthead light abaft of and higher than the forward one; except that a vessel of less than 50 meters in length shall not be obliged to exhibit such light but may do so;
  - (iii) sidelights; and
  - (iv) a sternlight.

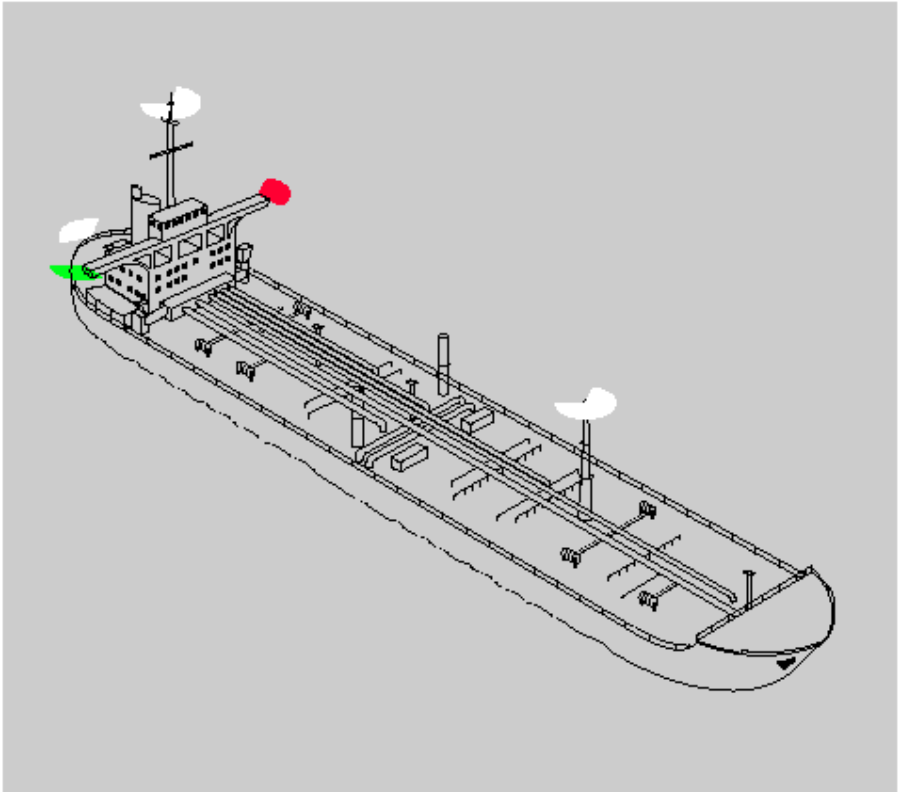

Power-driven vessel underway. Same for Inland.

# —INLAND—

## Lights and Shapes

### **RULE 23**

#### **Power-driven Vessels Underway**

- (a) A power-driven vessel underway shall exhibit:
- (i) a masthead light forward;
  - (ii) a second masthead light abaft of and higher than the forward one; except that a vessel of less than 50 meters in length shall not be obliged to exhibit such light but may do so;
  - (iii) sidelights; and
  - (iv) a sternlight.

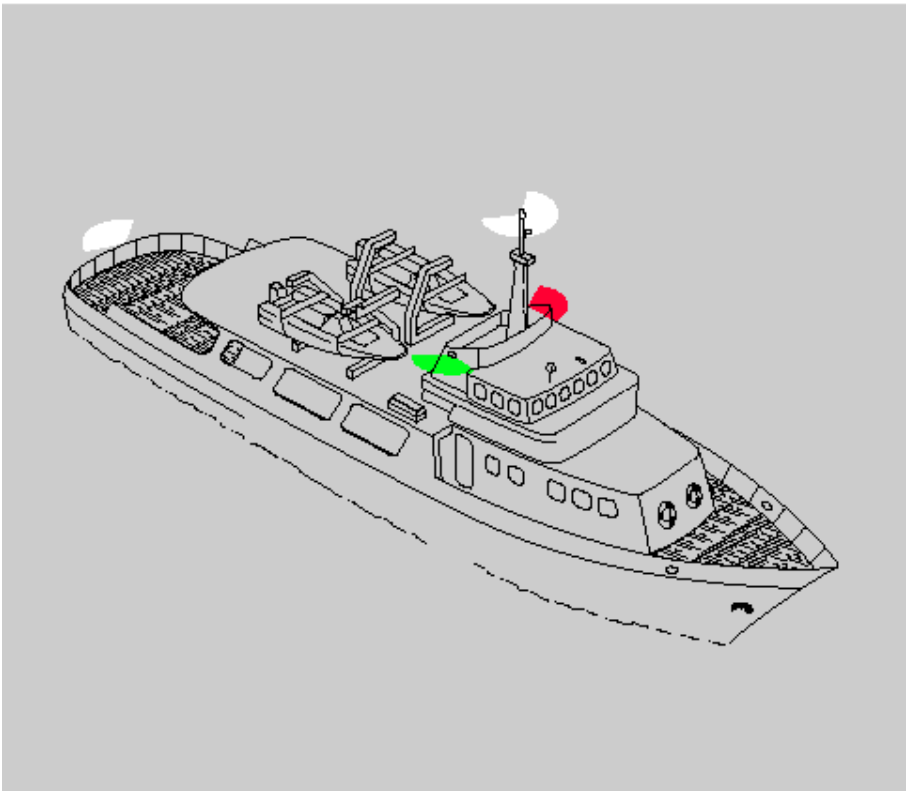

Power-driven vessel underway - less than 50 meters in length.  
Same for International.



# —INTERNATIONAL—

## Lights and Shapes

### RULE 23—CONTINUED

(b) An air-cushion vessel when operating in the nondisplacement mode shall, in addition to the lights prescribed in paragraph (a) of this Rule, exhibit an all-round flashing yellow light.

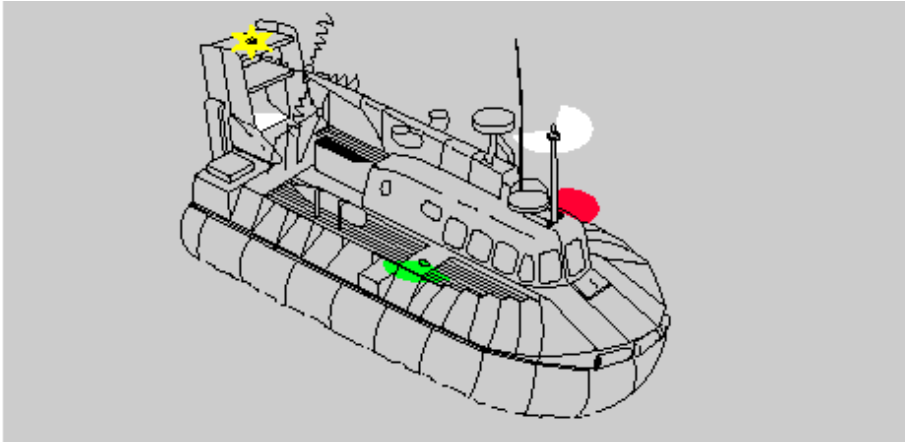

Air-cushion vessel when operating in the nondisplacement mode - vessel less than 50 meters in length.

# —INLAND—

## Lights and Shapes

### RULE 23—CONTINUED

(b) An air-cushion vessel when operating in the nondisplacement mode shall, in addition to the lights prescribed in paragraph (a) of this Rule, exhibit an all-round flashing yellow light where it can best be seen.

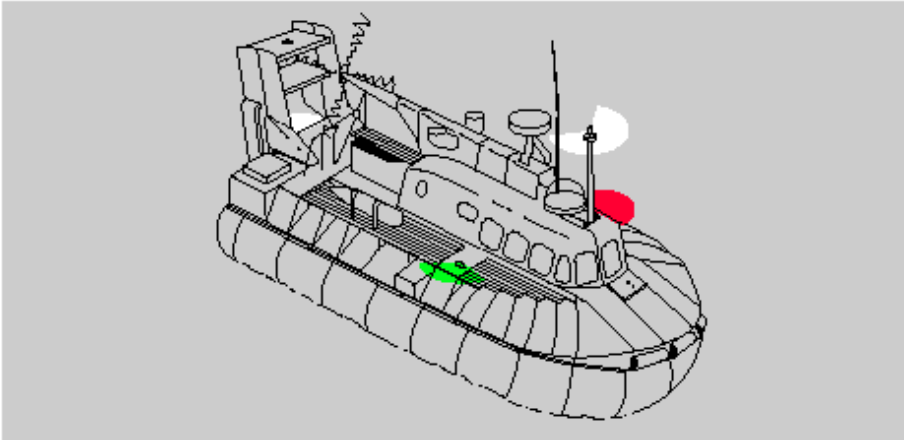

Air-cushion vessel when operating in the displacement mode - vessel less than 50 meters in length.

# —INTERNATIONAL—

## Lights and Shapes

### RULE 23—CONTINUED

(c) A WIG craft only when taking off, landing and in flight near the surface shall, in addition to the lights prescribed in paragraph (a) of this Rule, exhibit a high intensity all-round flashing red light.

(d)

(i) A power-driven vessel of less than 12 meters in length may in lieu of the lights prescribed in paragraph (a) of this Rule exhibit an all-round white light and sidelights;

(ii) a power-driven vessel of less than 7 meters in length whose maximum speed does not exceed 7 knots may in lieu of the lights prescribed in paragraph (a) of this Rule exhibit an all-round white light and shall, if practicable, also exhibit sidelights;

(iii) the masthead light or all-round white light on a power-driven vessel of less than 12 meters in length may be displaced from the fore and aft centerline of the vessel if centerline fitting is not practicable, provided that the sidelights are combined in one lantern which shall be carried on the fore and aft centerline of the vessel or located as nearly as practicable in the same fore and aft line as the masthead light or the all-round white light.

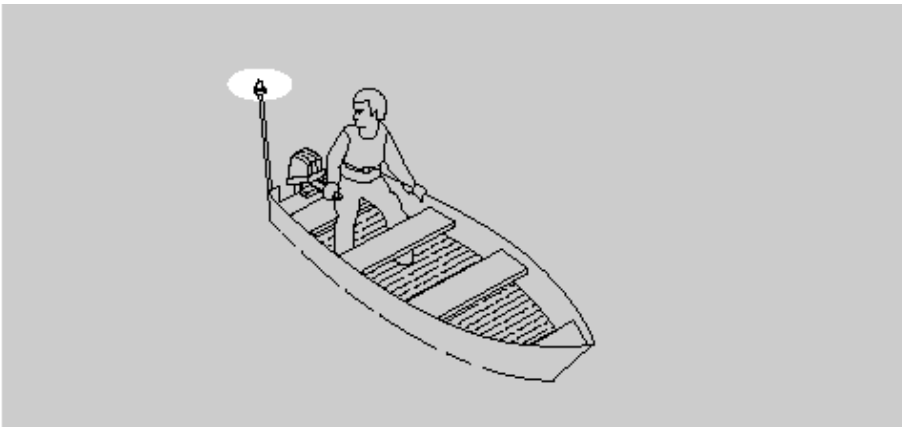

Power-driven vessel of less than 7 meters in length whose maximum speed does not exceed 7 knots.

# —INLAND—

## Lights and Shapes

### RULE 23—CONTINUED

(c) A power-driven vessel of less than 12 meters in length may, in lieu of the lights prescribed in paragraph (a) of this Rule, exhibit an all-round white light and sidelights.

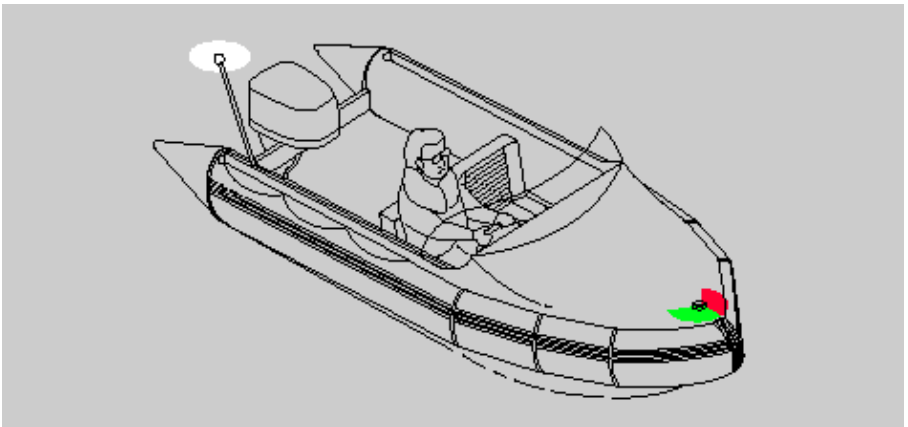

Power-driven vessel of less than 12 meters in length. Same for International.

# —INTERNATIONAL—

Lights and Shapes

[BLANK]

# —INLAND—

## Lights and Shapes

### RULE 23—CONTINUED

(d) A power-driven vessel when operating on the Great Lakes may carry an all-round white light in lieu of the second masthead light and sternlight prescribed in paragraph (a) of this Rule. The light shall be carried in the position of the second masthead light and be visible at the same minimum range.

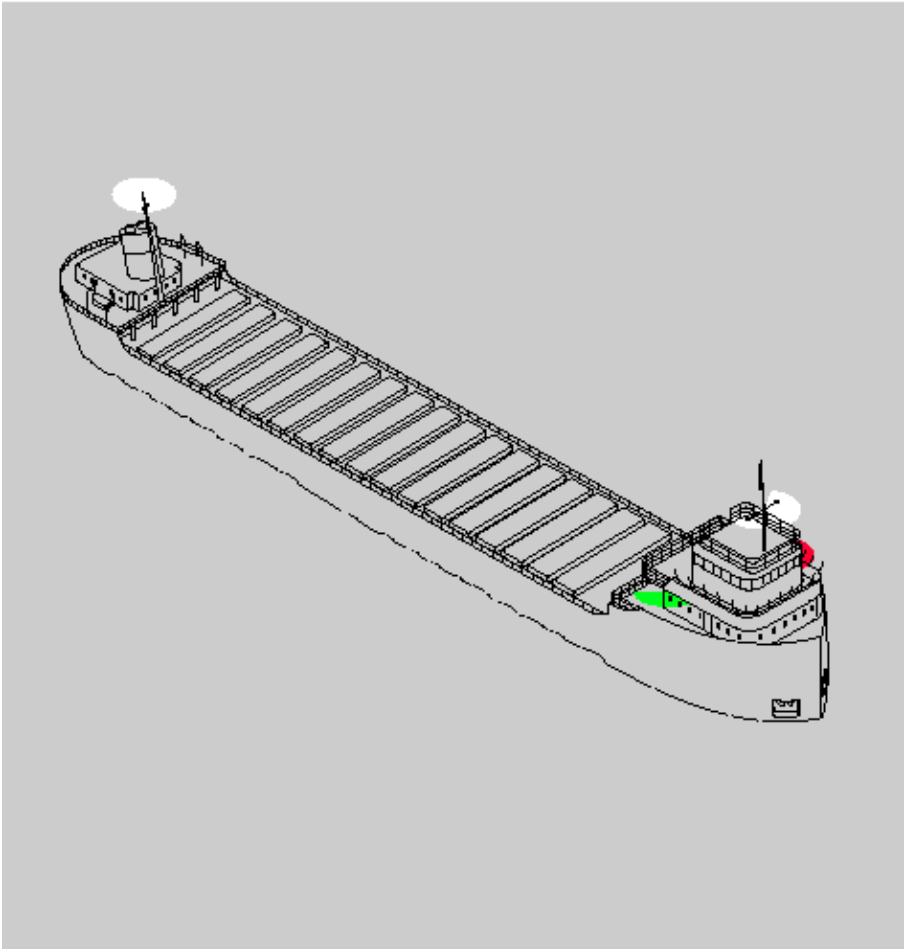

Power-driven vessel on Great Lakes.

# —INTERNATIONAL—

## Lights and Shapes

### **RULE 24** **Towing and Pushing**

- (a) A power-driven vessel when towing shall exhibit:
- (i) instead of the light prescribed in Rule 23(a)(i) or (a)(ii), two masthead lights in a vertical line. When the length of the tow, measuring from the stern of the towing vessel to the after end of the tow exceeds 200 meters, three such lights in a vertical line;
  - (ii) sidelights;
  - (iii) a sternlight;
  - (iv) a towing light in a vertical line above the sternlight; and (v) when the length of the tow exceeds 200 meters, a diamond shape where it can best be seen.

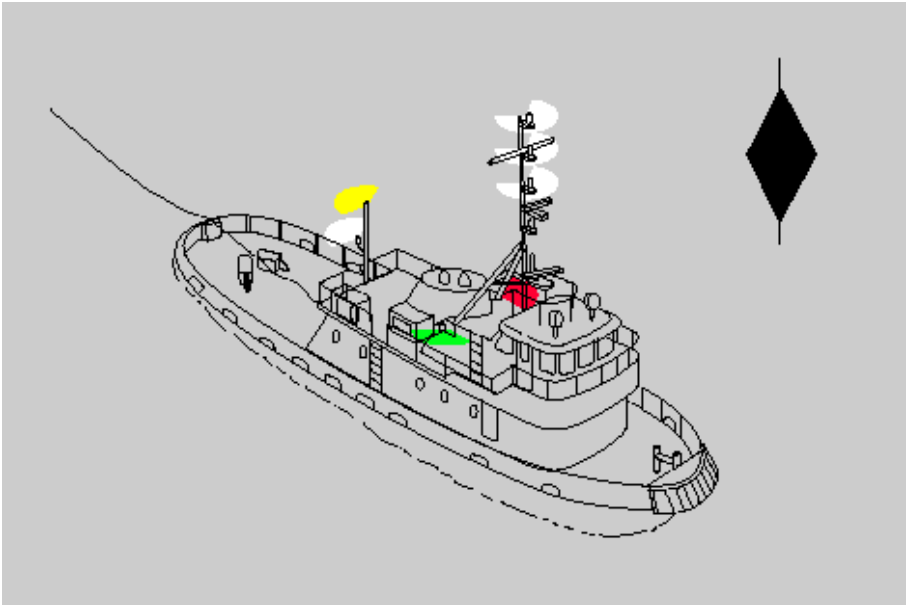

Power-driven vessel towing astern - towing vessel less than 50 meters in length; length of tow exceeds 200 meters. Same for Inland

# —INLAND—

## Lights and Shapes

### **RULE 24** **Towing and Pushing**

- (a) A power-driven vessel when towing astern shall exhibit:
- (i) instead of the light prescribed either in Rule 23(a)(i) or 23(a)(ii), two masthead lights in a vertical line. When the length of the tow, measuring from the stern of the towing vessel to the after end of the tow exceeds 200 meters, three such lights in a vertical line;
  - (ii) sidelights;
  - (iii) a sternlight;
  - (iv) a towing light in a vertical line above the sternlight; and (v) when the length of the tow exceeds 200 meters, a diamond shape where it can best be seen.

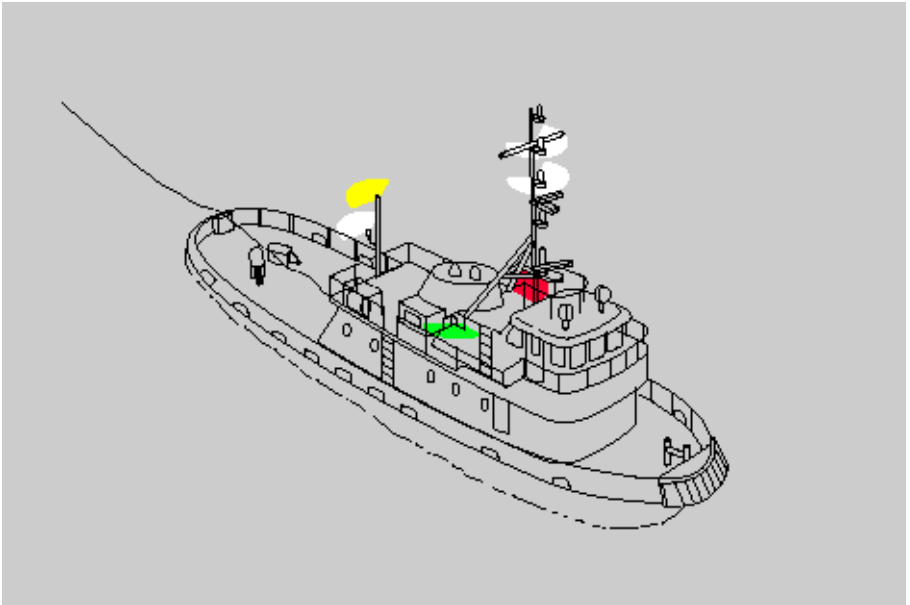

Power-driven vessel towing astern - towing vessel less than 50 meters in length; length of tow 200 meters or less. Same for International.



# —INTERNATIONAL—

## Lights and Shapes

### RULE 24—CONTINUED

(b) When a pushing vessel and a vessel being pushed ahead are rigidly connected in a composite unit they shall be regarded as a power-driven vessel and exhibit the lights prescribed in Rule 23.

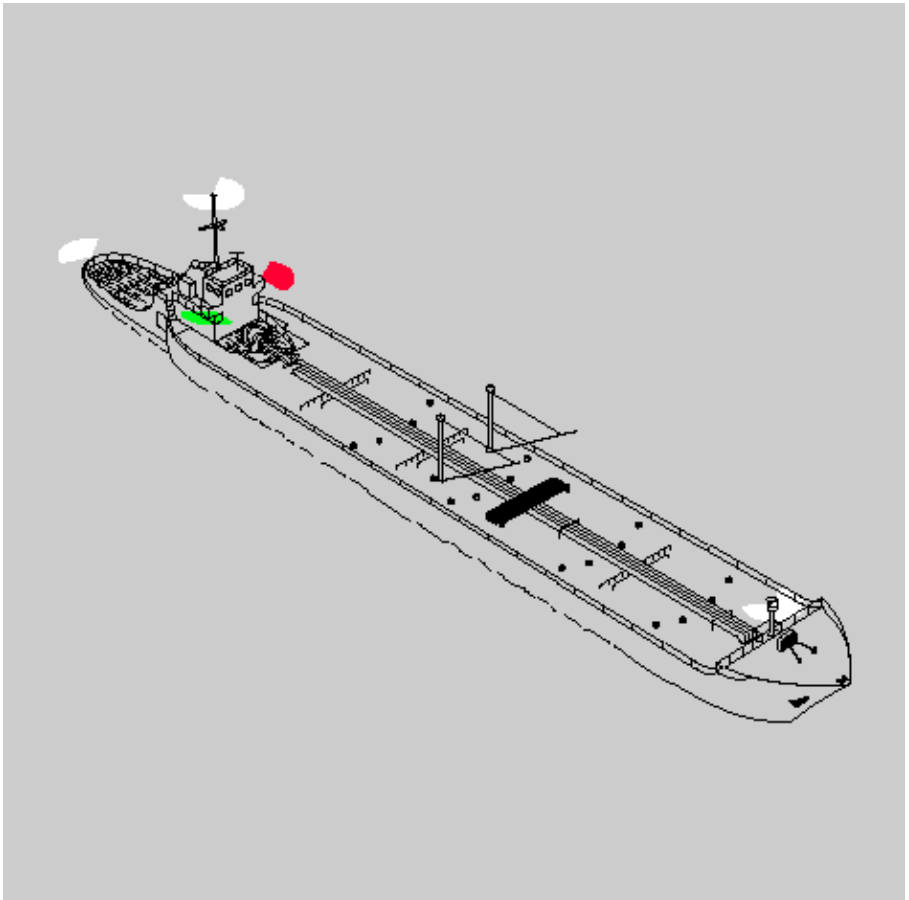

Composite unit underway. Same for Inland.

# —INLAND—

## Lights and Shapes

### RULE 24—CONTINUED

(b) When a pushing vessel and a vessel being pushed ahead are rigidly connected in a composite unit they shall be regarded as a power-driven vessel and exhibit the lights prescribed in Rule 23.

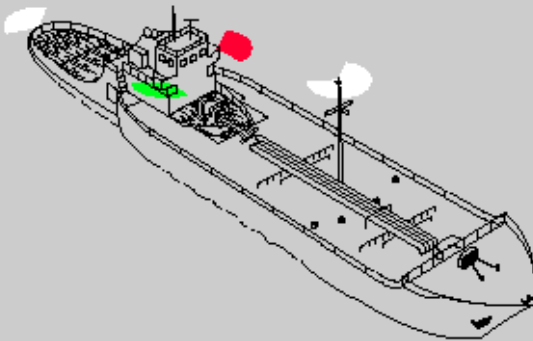

Composite unit underway - less than 50 meters in length.  
Same for International.

# —INTERNATIONAL—

## Lights and Shapes

### RULE 24—CONTINUED

(c) A power-driven vessel when pushing ahead or towing alongside, except in the case of a composite unit, shall exhibit:

- (i) instead of the light prescribed in Rule 23(a)(i) or 23(a)(ii), two masthead lights in a vertical line;
- (ii) sidelights; and
- (iii) a sternlight.

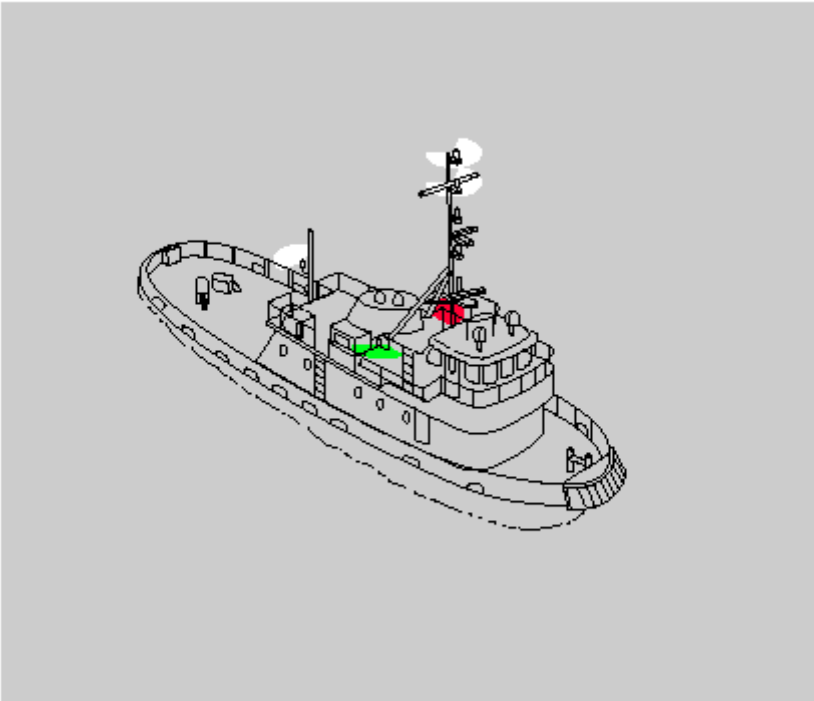

Power-driven vessel pushing ahead or towing alongside—towing vessel less than 50 meters in length.

# —INLAND—

## Lights and Shapes

### RULE 24—CONTINUED

- (c) A power-driven vessel when pushing ahead or towing alongside, except as required by paragraphs (b) and (i) of this Rule, shall exhibit:
- (i) instead of the light prescribed either in Rule 23(a)(i) or 23(a)(ii), two masthead lights in a vertical line;
  - (ii) sidelights; and
  - (iii) two towing lights in a vertical line.

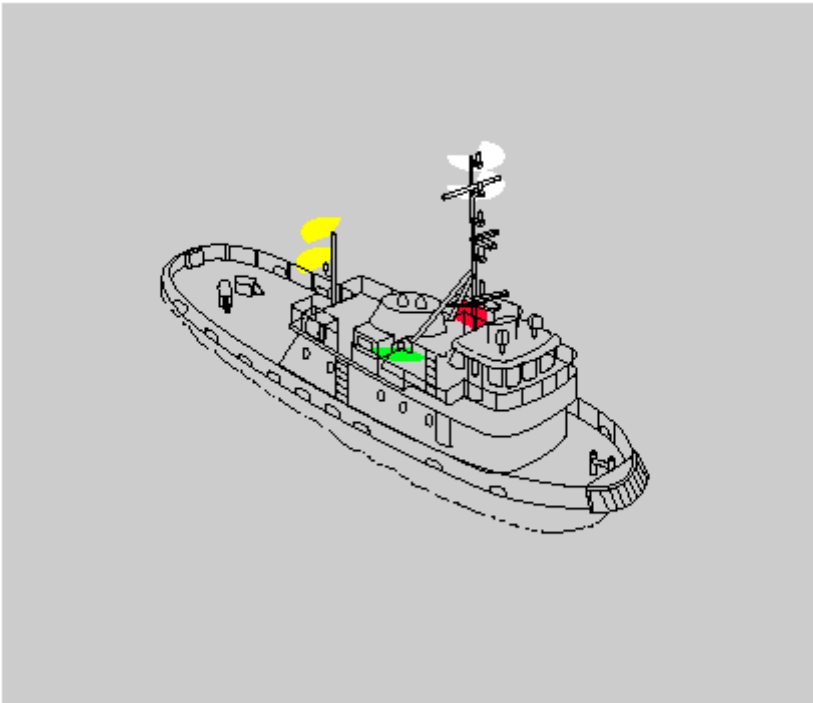

Power-driven vessel pushing ahead or towing alongside—towing vessel less than 50 meters in length.

# —INTERNATIONAL—

## Lights and Shapes

### RULE 24—CONTINUED

(d) A power-driven vessel to which paragraph (a) or (c) of this Rule apply shall also comply with Rule 23(a)(ii).

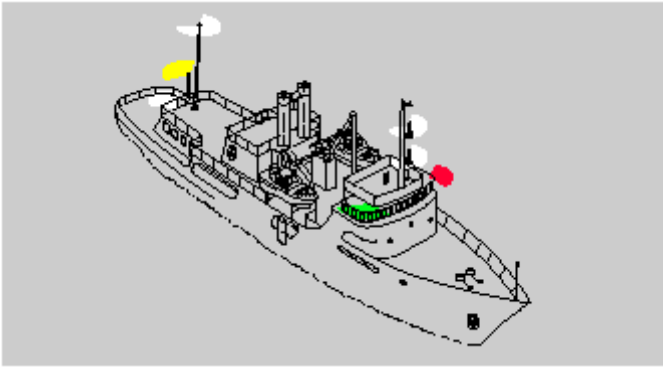

Power-driven vessel towing astern—length of tow 200 meters or less. The after masthead light is optional for vessel less than 50 meters in length. Same for Inland.

(e) A vessel or object being towed, other than those mentioned in paragraph (g) of this Rule, shall exhibit:

- (i) sidelights;
- (ii) a sternlight;
- (iii) when the length of the tow exceeds 200 meters, a diamond shape where it can best be seen.

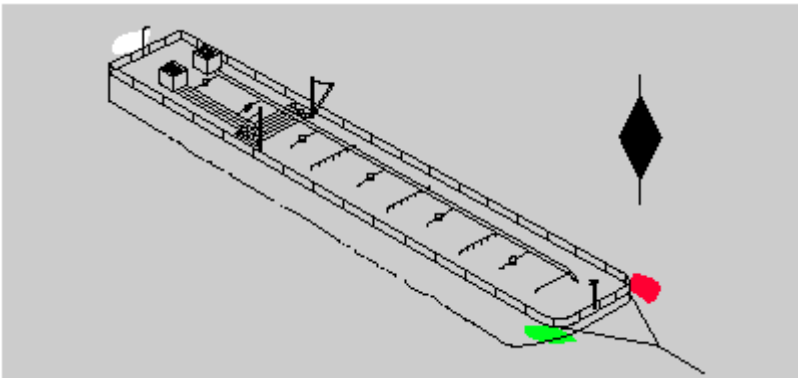

Vessel or object being towed—length of tow exceeds 200 meters. Same for Inland.

# —INLAND—

## Lights and Shapes

### RULE 24—CONTINUED

A power-driven vessel to which paragraphs (a) or (c) of this Rule apply shall also comply with Rule 23(a)(i) and 23(a)(ii).

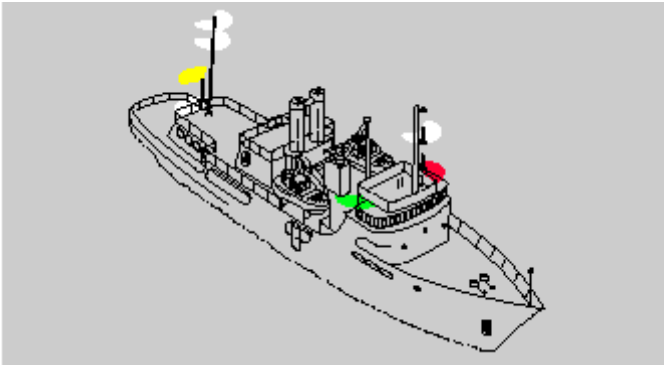

Power-driven vessel towing astern—length of tow 200 meters or less. When masthead lights for towing or pushing are exhibited aft, a forward masthead light is required. Same for International.

(d) A vessel or object other than those referred to in paragraph (g) of this Rule being towed shall exhibit:

- (i) sidelights;
- (ii) a sternlight; and
- (iii) when the length of the tow exceeds 200 meters, a diamond shape where it can best be seen.

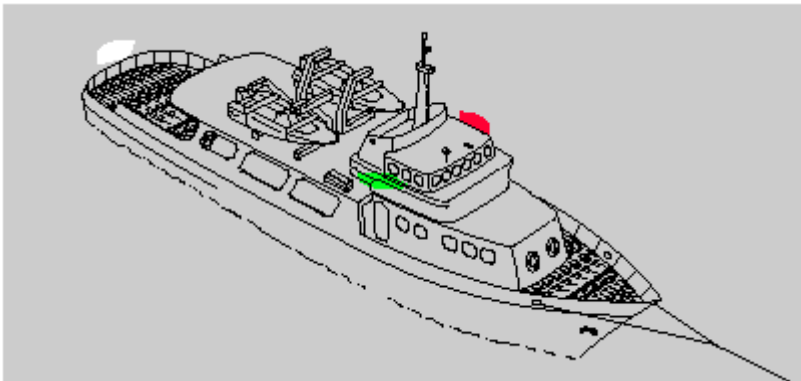

Vessel being towed—length of tow 200 meters or less. Same for International.

# —INTERNATIONAL—

## Lights and Shapes

### RULE 24—CONTINUED

(f) Provided that any number of vessels being towed alongside or pushed in a group shall be lighted as one vessel:

(i) a vessel being pushed ahead, not being part of a composite unit, shall exhibit at the forward end, sidelights;

(ii) a vessel being towed alongside shall exhibit a sternlight and at the forward end, sidelights.

# —INLAND—

## Lights and Shapes

### RULE 24—CONTINUED

(e) Provided that any number of vessels being towed alongside or pushed in a group shall be lighted as one vessel, except as provided in paragraph (iii):

- (i) a vessel being pushed ahead, not being part of a composite unit, shall exhibit at the forward end sidelights, and a special flashing light;
- (ii) a vessel being towed alongside shall exhibit a sternlight and at the forward end, sidelights and a special flashing light; and
- (iii) when vessels are towed alongside on both sides of the towing vessels a sternlight shall be exhibited on the stern of the outboard vessel on each side of the towing vessel, and a single set of sidelights as far forward and as far outboard as is practicable, and a single special flashing light.



# —INTERNATIONAL—

## Lights and Shapes

### RULE 24—CONTINUED

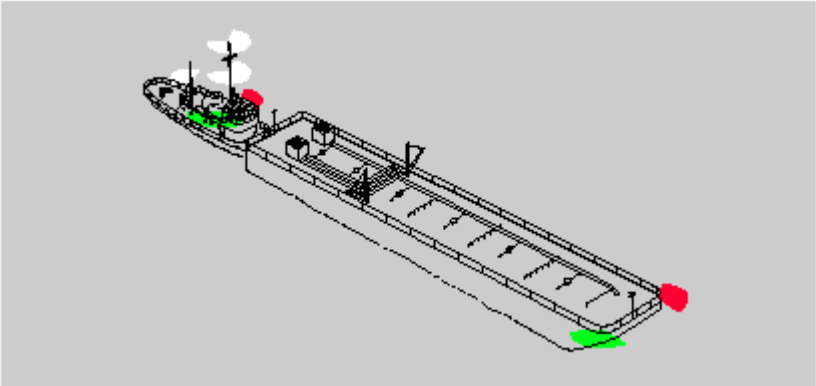

Vessel being pushed ahead, not being part of a composite unit.

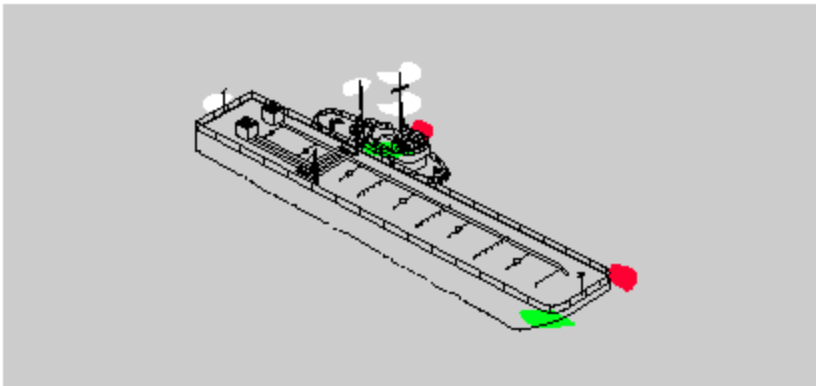

Vessel being towed alongside.

—INLAND—  
Lights and Shapes

RULE 24—CONTINUED

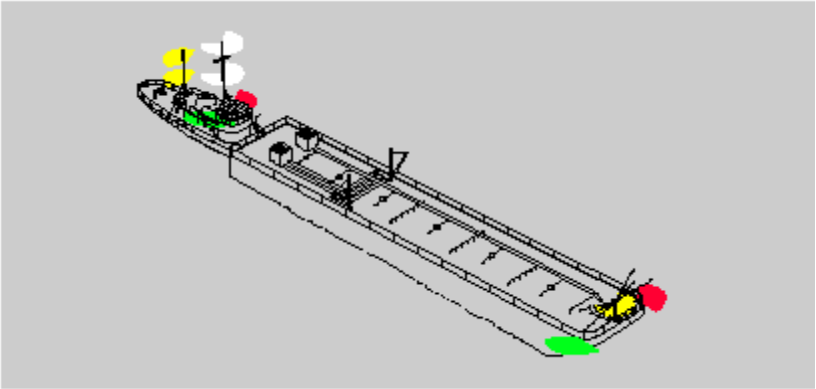

Vessel being pushed ahead, not being part of a composite unit.

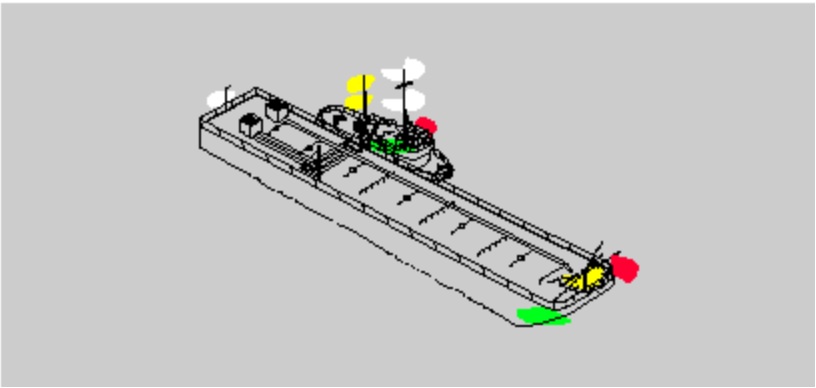

Vessel being towed alongside.

# —INTERNATIONAL—

## Lights and Shapes

### RULE 24—CONTINUED

(g) An inconspicuous, partly submerged vessel or object, or combination of such vessels or objects being towed, shall exhibit:

(h) if it is less than 25 meters in breadth, one all-round white light at or near the forward end and one at or near the after end except that dracones need not exhibit a light at or near the forward end;

(i) if it is 25 meters or more in breadth, two additional all-round white lights at or near the extremities of its breadth;

(ii) if it exceeds 100 meters in length, additional all-round white lights between the lights prescribed in subparagraphs (i) and (ii) so that the distance between the lights shall not exceed 100 meters;

(iii) a diamond shape at or near the aftermost extremity of the last vessel or object being towed and if the length of the tow exceeds 200 meters an additional diamond shape where it can best be seen and located as far forward as is practicable.

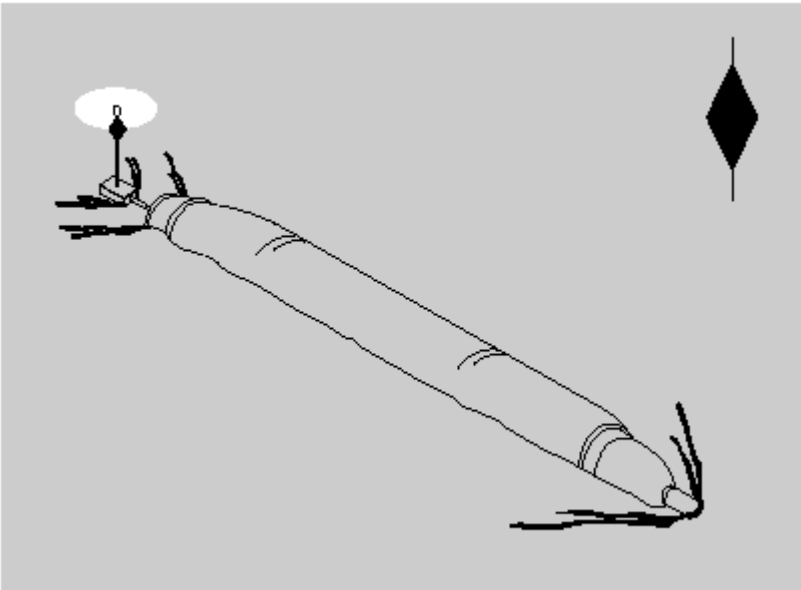

Dracone being towed.

# —INLAND—

## Lights and Shapes

### RULE 24—CONTINUED

(f) An inconspicuous, partly submerged vessel or object being towed shall exhibit:

(g) if it is less than 25 meters in breadth, one all-round white light at or near each end;

(i) if it is 25 meters or more in breadth, four all-round white lights to mark its length and breadth;

(ii) if it exceeds 100 meters in length, additional all-round white lights between the lights prescribed in subparagraphs (i) and (ii) so that the distance between the lights shall not exceed 100 meters: Provided, That any vessels or objects being towed alongside each other shall be lighted as one vessel or object;

(iii) a diamond shape at or near the aftermost extremity of the last vessel or object being towed; and (v) the towing vessel may direct a searchlight in the direction of the tow to indicate its presence to an approaching vessel.

# —INTERNATIONAL—

## Lights and Shapes

### RULE 24—CONTINUED

(h) Where from any sufficient cause it is impracticable for a vessel or object being towed to exhibit the lights or shapes prescribed in paragraph (e) or (g) of this Rule, all possible measures shall be taken to light the vessel or object towed or at least to indicate the presence of such vessel or object.

# —INLAND—

## Lights and Shapes

### RULE 24—CONTINUED

(h) Where from any sufficient cause it is impracticable for a vessel or object being towed to exhibit the lights prescribed in paragraph (e) or (g) of this Rule, all possible measures shall be taken to light the vessel or object towed or at least to indicate the presence of the unlighted vessel or object.

—INTERNATIONAL—  
Lights and Shapes

RULE 24—CONTINUED

[BLANK]

# —INLAND—

## Lights and Shapes

### RULE 24—CONTINUED

(i) Notwithstanding paragraph (c), on the Western Rivers (except below the Huey P. Long Bridge on the Mississippi River) and on waters specified by the Secretary, a power-driven vessel when pushing ahead or towing alongside, except as paragraph (b) applies, shall exhibit:

- (i) sidelights; and
- (ii) two towing lights in a vertical line.

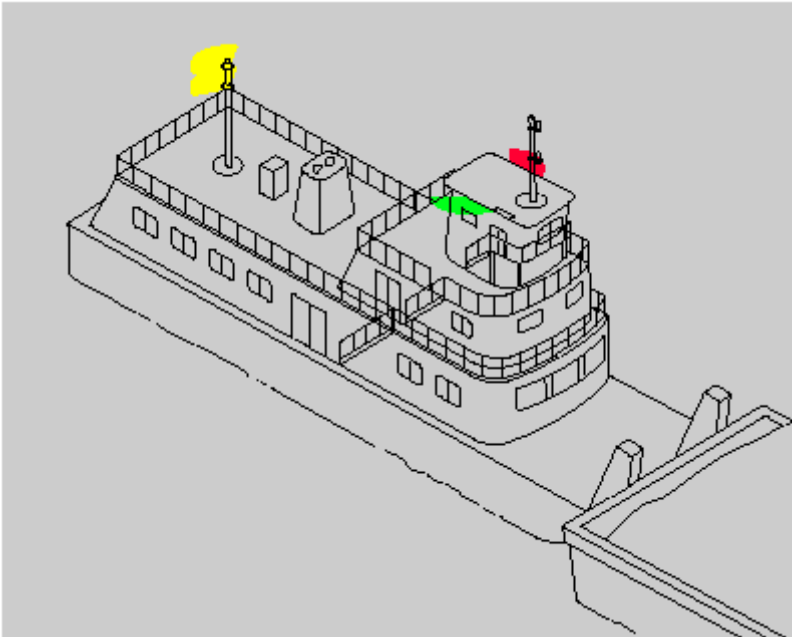

Power-driven vessel pushing ahead on Western Rivers. (above the Huey P. Long Bridge on the Mississippi River)



# —INTERNATIONAL—

## Lights and Shapes

### RULE 24—CONTINUED

(i) Where from any sufficient cause it is impracticable for a vessel not normally engaged in towing operations to display the lights prescribed in paragraph (a) or (c) of this Rule, such vessel shall not be required to exhibit those lights when engaged in towing another vessel in distress or otherwise in need of assistance. All possible measures shall be taken to indicate the nature of the relationship between the towing vessel and the vessel being towed as authorized by Rule 36, in particular by illuminating the towline.

# —INLAND—

## Lights and Shapes

### RULE 24—CONTINUED

(j) Where from any sufficient cause it is impracticable for a vessel not normally engaged in towing operations to display the lights prescribed by paragraph (a), (c) or (i) of this Rule, such vessel shall not be required to exhibit those lights when engaged in towing another vessel in distress or otherwise in need of assistance. All possible measures shall be taken to indicate the nature of the relationship between the towing vessel and the vessel being assisted. The searchlight authorized by Rule 36 may be used to illuminate the tow.

# —INTERNATIONAL—

## Lights and Shapes

### RULE 25

#### **Sailing Vessels Underway and Vessels Under Oars**

(a) A sailing vessel underway shall exhibit:

- (i) sidelights;
- (ii) a stern light.

(b) In a sailing vessel of less than 20 meters in length the lights prescribed in paragraph (a) of this Rule may be combined in one lantern carried at or near the top of the mast where it can best be seen.

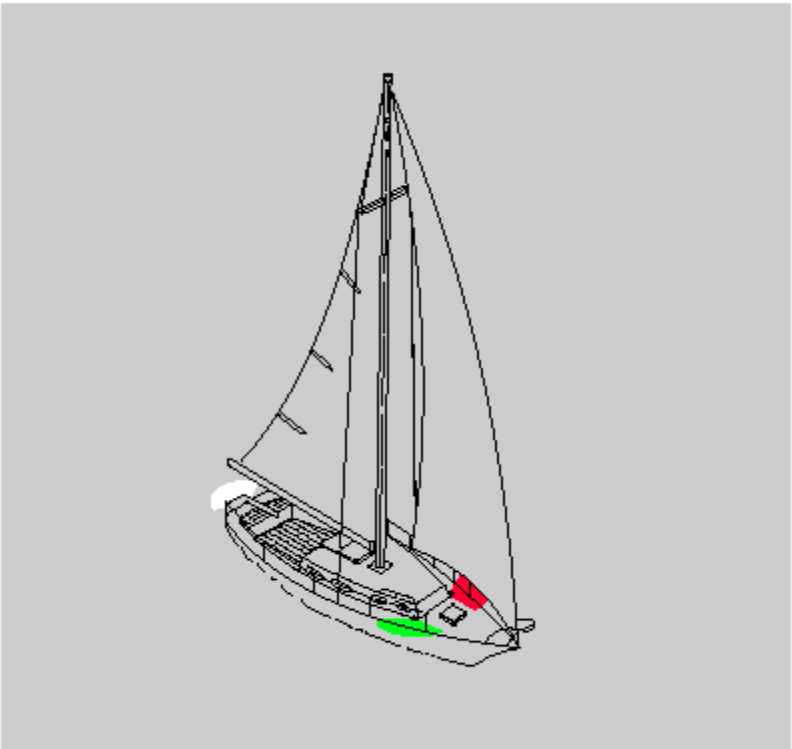

Sailing vessel underway. Same for Inland.

# —INLAND—

## Lights and Shapes

### RULE 25

#### **Sailing Vessels Underway and Vessels Under Oars**

(a) A sailing vessel underway shall exhibit:

- (i) sidelights; and
- (ii) a stern light.

(b) In a sailing vessel of less than 20 meters in length the lights prescribed in paragraph (a) of this Rule may be combined in one lantern carried at or near the top of the mast where it can best be seen.

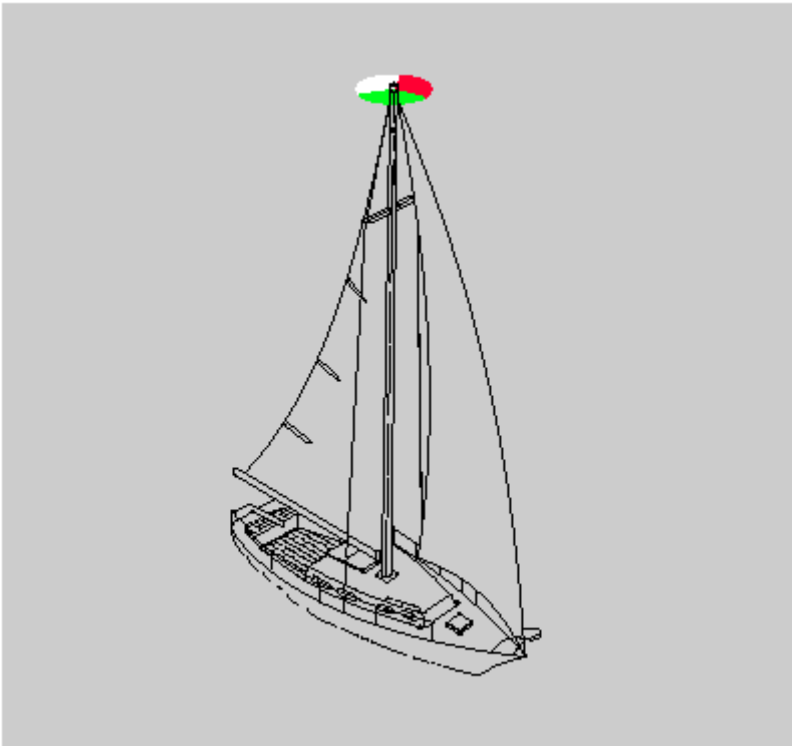

Sailing vessel underway—less than 20 meters in length.  
Same for International.

# —INTERNATIONAL—

## Lights and Shapes

### RULE 25—CONTINUED

(c) A sailing vessel underway may, in addition to the lights prescribed in paragraph (a) of this Rule, exhibit at or near the top of the mast, where they can best be seen, two all-round lights in a vertical line, the upper being red and the lower green, but these lights shall not be exhibited in conjunction with the combined lantern permitted by paragraph (b) of this Rule.

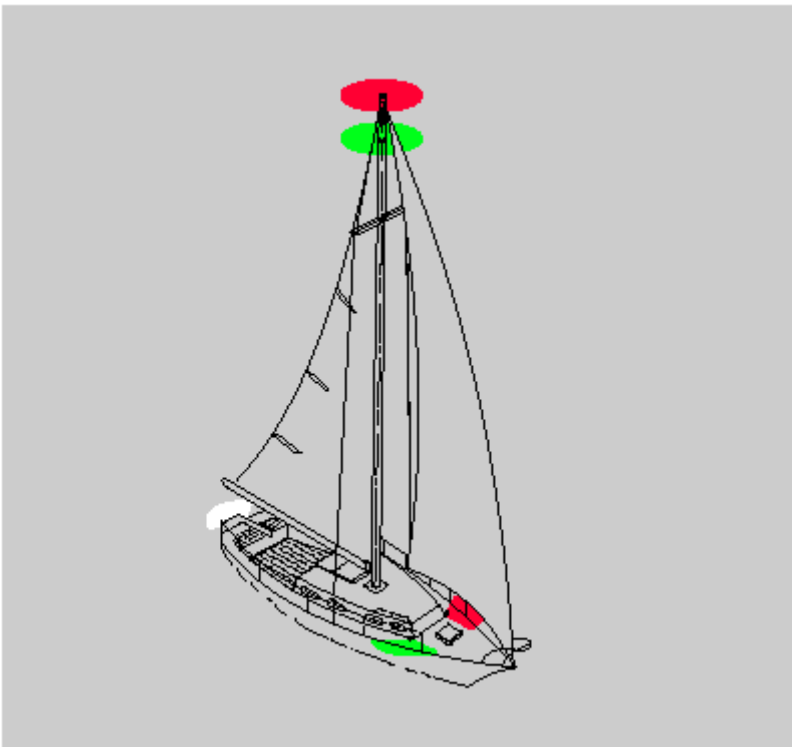

Sailing vessel underway. Same for Inland.

# —INLAND—

## Lights and Shapes

### RULE 25—CONTINUED

(c) A sailing vessel underway may, in addition to the lights prescribed in paragraph (a) of this Rule, exhibit at or near the top of the mast, where they can best be seen, two all-round lights in a vertical line, the upper being red and the lower green, but these lights shall not be exhibited in conjunction with the combined lantern permitted by paragraph (b) of this Rule.

# —INTERNATIONAL—

## Lights and Shapes

### RULE 25—CONTINUED

(d)

(i) A sailing vessel of less than 7 meters in length shall, if practicable, exhibit the lights prescribed in paragraph (a) or (b) of this Rule, but if she does not, she shall have ready at hand an electric torch or lighted lantern showing a white light which shall be exhibited in sufficient time to prevent collision.

(ii) A vessel under oars may exhibit the lights prescribed in this Rule for sailing vessels, but if she does not, she shall have ready at hand an electric torch or lighted lantern showing a white light which shall be exhibited in sufficient time to prevent collision.

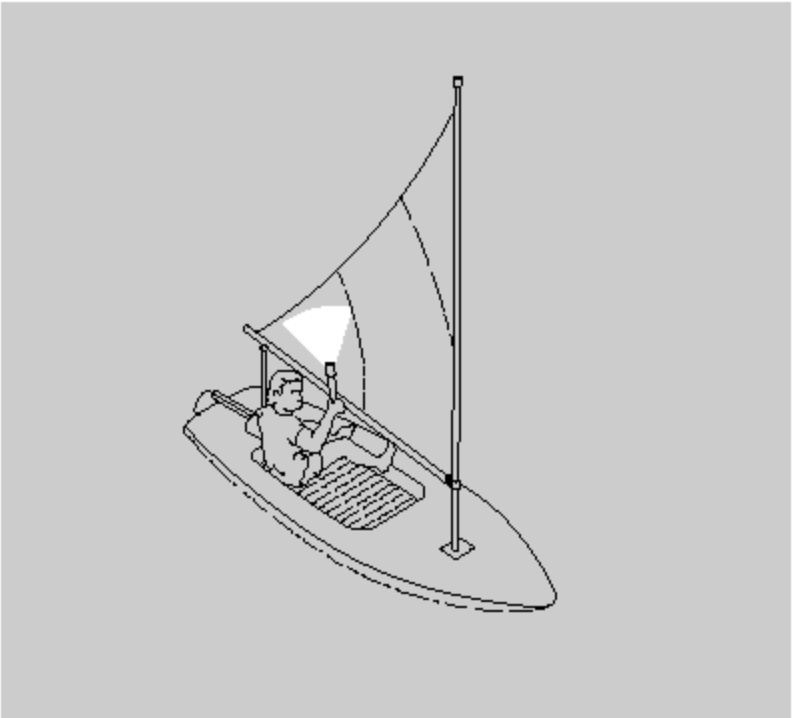

Sailing vessel underway—less than 7 meters in length.  
Same for Inland.

# —INLAND—

## Lights and Shapes

### RULE 25—CONTINUED

(d)

(i) A sailing vessel of less than 7 meters in length shall, if practicable, exhibit the lights prescribed in paragraph (a) or (b) of this Rule, but if she does not, she shall have ready at hand an electric torch or lighted lantern showing a white light which shall be exhibited in sufficient time to prevent collision.

(ii) A vessel under oars may exhibit the lights prescribed in this Rule for sailing vessels, but if she does not, she shall have ready at hand an electric torch or lighted lantern showing a white light which shall be exhibited in sufficient time to prevent collision.

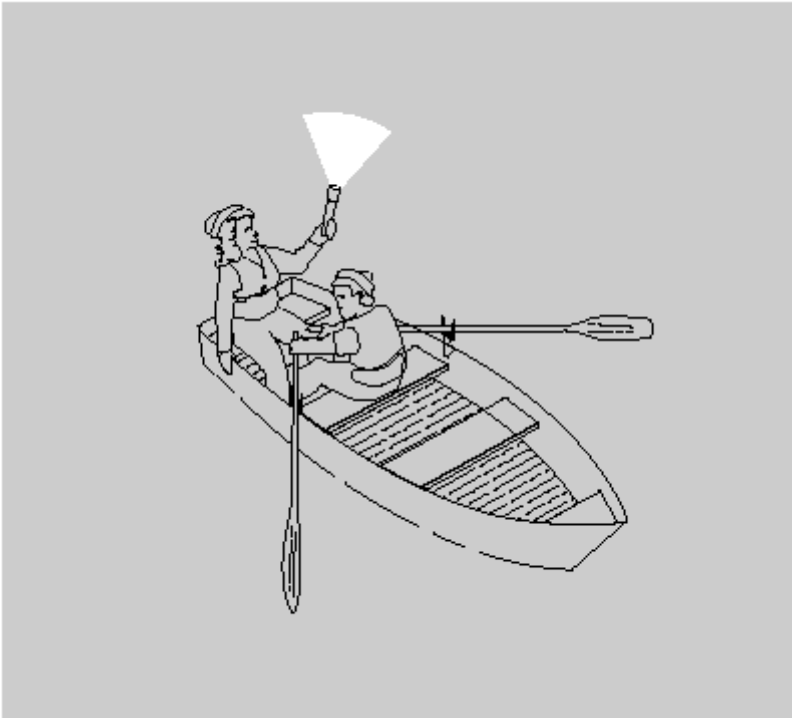

Vessel under oars. Same for International.



# —INTERNATIONAL—

## Lights and Shapes

### RULE 25—CONTINUED

(e) A vessel proceeding under sail when also being propelled by machinery shall exhibit forward where it can best be seen a conical shape, apex downwards.

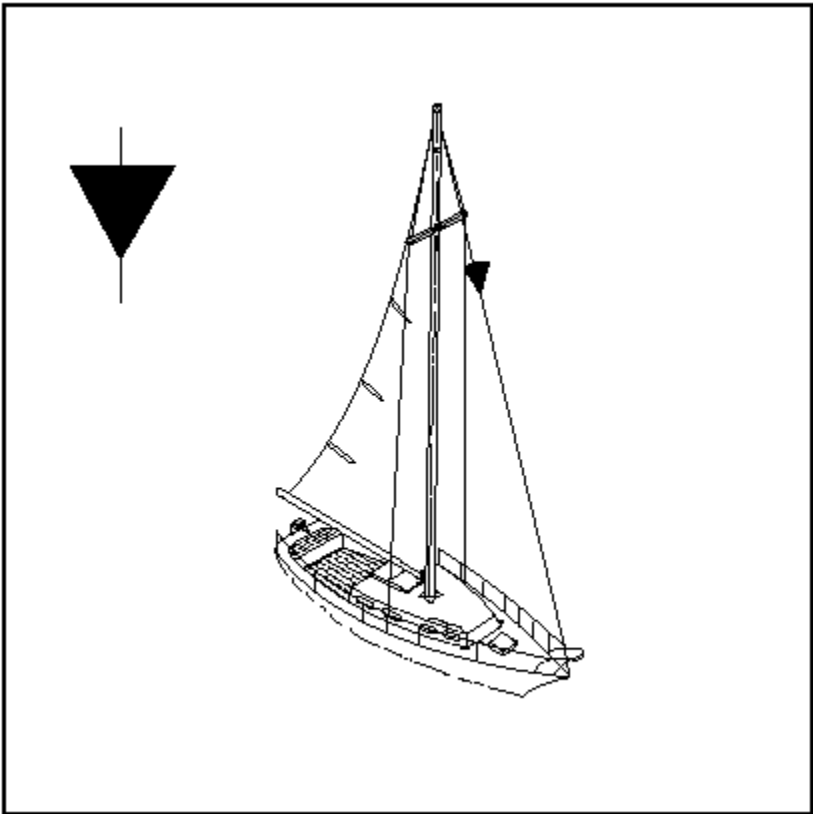

Vessel proceeding under sail when also being propelled by machinery. Same for Inland except that a vessel of less than 12 meters in length is not required to exhibit the dayshape.

# —INLAND—

## Lights and Shapes

### RULE 25—CONTINUED

(e) A vessel proceeding under sail when also being propelled by machinery shall exhibit forward where it can best be seen a conical shape, apex downward. A vessel of less than 12 meters in length is not required to exhibit this shape, but may do so.

# —INTERNATIONAL—

## Lights and Shapes

### **RULE 26** **Fishing Vessels**

(a) A vessel engaged in fishing, whether underway or at anchor, shall exhibit only the lights and shapes prescribed in this Rule.

(b) A vessel when engaged in trawling, by which is meant the dragging through the water of a dredge net or other apparatus used as a fishing appliance, shall exhibit:

(i) two all-round lights in a vertical line, the upper being green and the lower white, or a shape consisting of two cones with their apexes together in a vertical line one above the other;

(ii) a masthead light abaft of and higher than the all-round green light; a vessel of less than 50 meters in length shall not be obliged to exhibit such a light but may do so;

(iii) when making way through the water, in addition to the lights prescribed in this paragraph, sidelights and a sternlight.

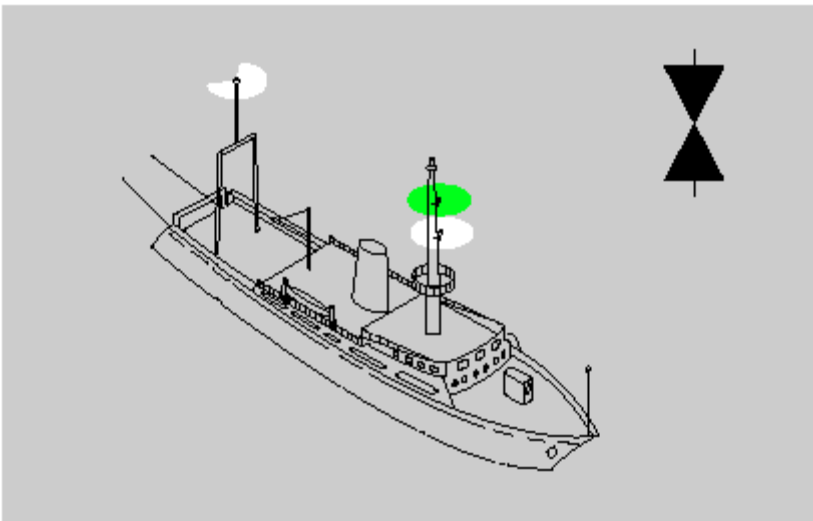

Vessel engaged in trawling—not making way. Same for Inland.

# —INLAND—

## Lights and Shapes

### **RULE 26** **Fishing Vessels**

(a) A vessel engaged in fishing, whether underway or at anchor, shall exhibit only the lights and shapes prescribed in this Rule.

(b) A vessel when engaged in trawling, by which is meant the dragging through the water of a dredge net or other apparatus used as a fishing appliance, shall exhibit:

(i) two all-round lights in a vertical line, the upper being green and the lower white, or a shape consisting of two cones with their apexes together in a vertical line one above the other;

(ii) a masthead light abaft of and higher than the all-round green light; a vessel of less than 50 meters in length shall not be obliged to exhibit such a light but may do so; and

(iii) when making way through the water, in addition to the lights prescribed in this paragraph, sidelights and a sternlight.

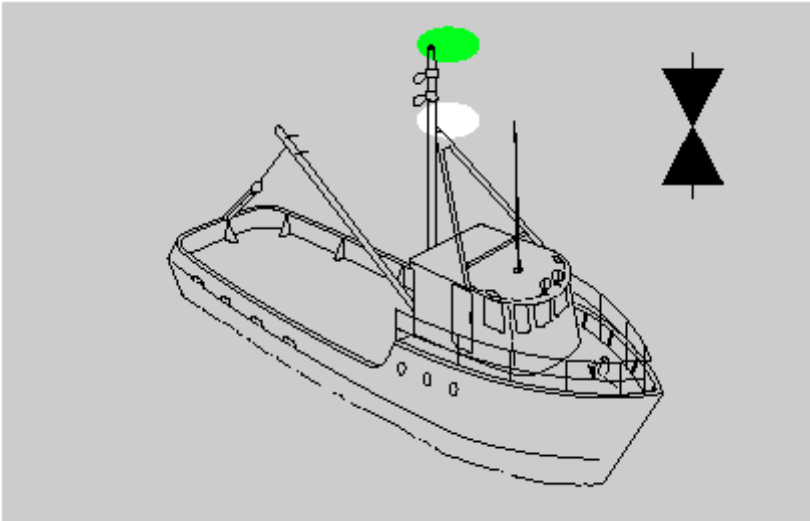

Vessel engaged in trawling—not making way; vessel less than 50 meters in length. Same for International.

# —INTERNATIONAL—

## Lights and Shapes

### RULE 26—CONTINUED

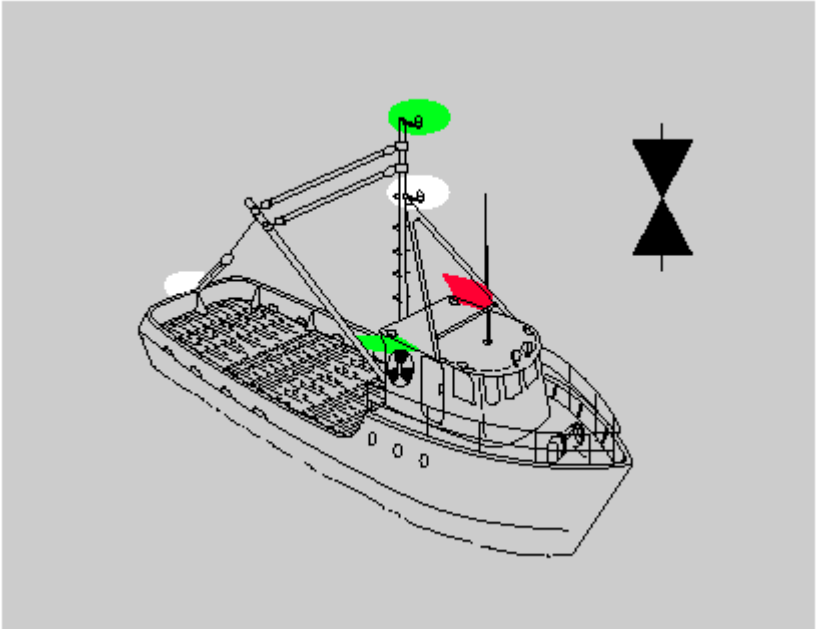

Vessel engaged in trawling—making way; vessel less than 50 meters in length. Same for Inland.

—INLAND—  
Lights and Shapes

RULE 26—CONTINUED

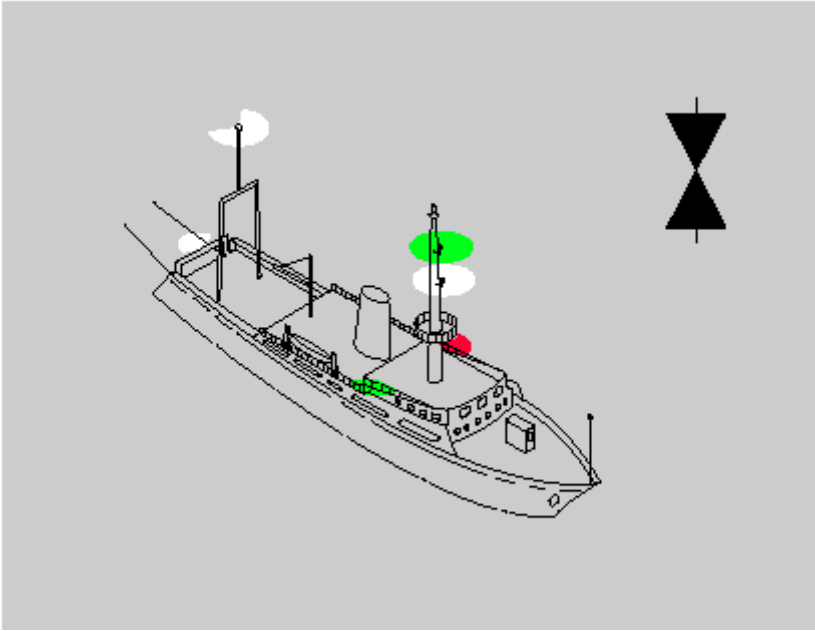

Vessel engaged in trawling—making way. Same for International.

# —INTERNATIONAL—

## Lights and Shapes

### RULE 26—CONTINUED

- (c) A vessel engaged in fishing, other than trawling, shall exhibit:
- (i) two all-round lights in a vertical line, the upper being red and the lower white, or a shape consisting of two cones with apexes together in a vertical line one above the other;
  - (ii) when there is outlying gear extending more than 150 meters horizontally from the vessel, an all-round white light or a cone apex upwards in the direction of the gear;
  - (iii) when making way through the water, in addition to the lights prescribed in this paragraph, sidelights and a sternlight.

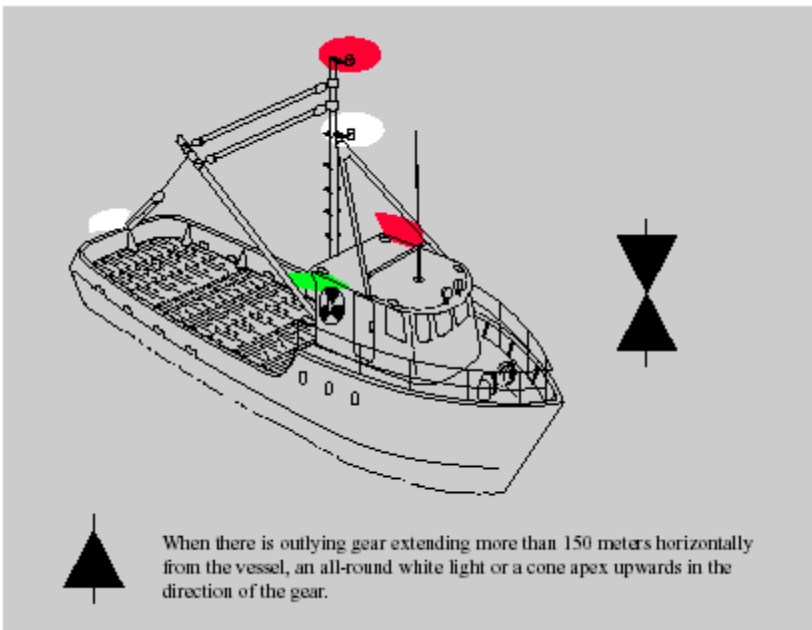

Vessel engaged in fishing other than trawling—making way.  
Same for Inland.

# —INLAND—

## Lights and Shapes

### RULE 26—CONTINUED

- (c) A vessel engaged in fishing, other than trawling, shall exhibit:
- (i) two all-round lights in a vertical line, the upper being red and the lower white, or a shape consisting of two cones with apexes together in a vertical line one above the other;
  - (ii) when there is outlying gear extending more than 150 meters horizontally from the vessel, an all-round white light or a cone apex upward in the direction of the gear; and
  - (iii) when making way through the water, in addition to the lights prescribed in this paragraph, sidelights and a sternlight.

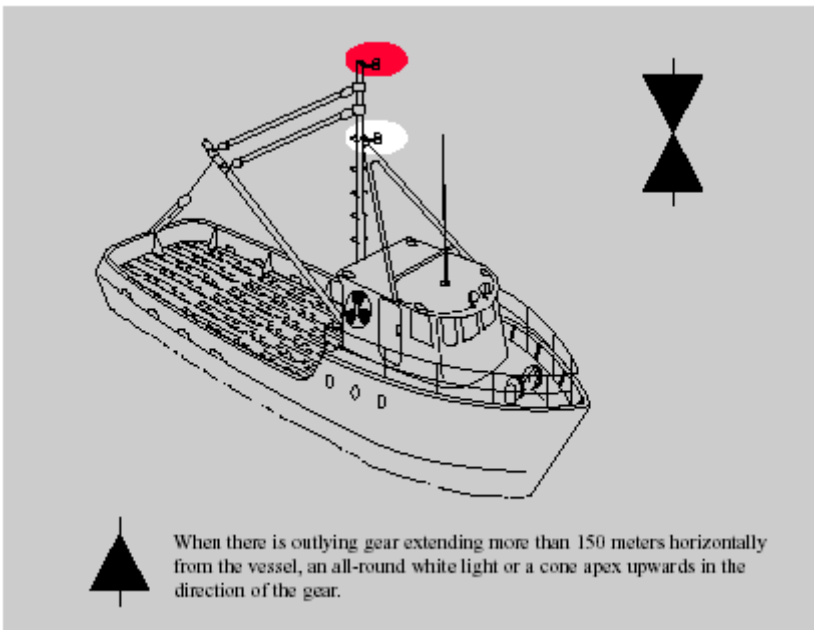

Vessel engaged in fishing other than trawling—not making way.  
Same for International.



# —INTERNATIONAL—

## Lights and Shapes

### RULE 26—CONTINUED

(d) The additional signals described in Annex II to these Rules apply to a vessel engaged in fishing in close proximity to other vessels engaged in fishing.

(e) A vessel when not engaged in fishing shall not exhibit the lights or shapes prescribed in this Rule, but only those prescribed for a vessel of her length.

# —INLAND—

## Lights and Shapes

### RULE 26—CONTINUED

(d) The additional signals described in Annex II to these Rules apply to a vessel engaged in fishing in close proximity to other vessels engaged in fishing.

(e) A vessel when not engaged in fishing shall not exhibit the lights or shapes prescribed in this Rule, but only those prescribed for a vessel of her length.

# —INTERNATIONAL—

## Lights and Shapes

### RULE 27

#### Vessels Not Under Command or Restricted in Their Ability to Maneuver

- (a) A vessel not under command shall exhibit:
- (i) two all-round red lights in a vertical line where they can best be seen;
  - (ii) two balls or similar shapes in a vertical line where they can best be seen;
  - (iii) when making way through the water, in addition to the lights prescribed in this paragraph, sidelights and a sternlight.

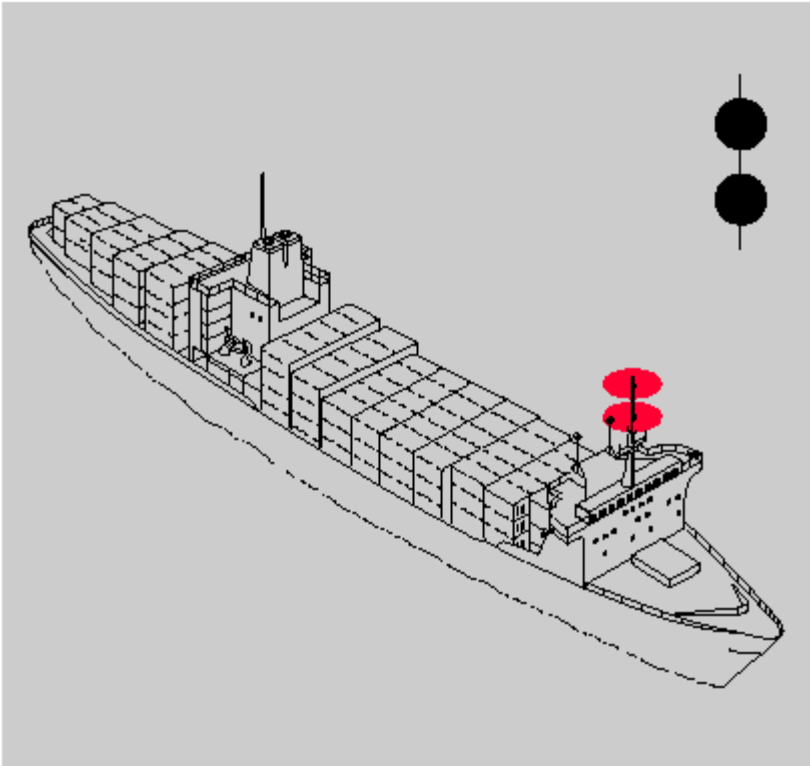

Vessel not under command—not making way. Same for Inland.

# —INLAND—

## Lights and Shapes

### **RULE 27**

#### **Vessels Not Under Command or Restricted in Their Ability to Maneuver**

- (a) A vessel not under command shall exhibit:
- (i) two all-round red lights in a vertical line where they can best be seen;
  - (ii) two balls or similar shapes in a vertical line where they can best be seen; and
  - (iii) when making way through the water, in addition to the lights prescribed in this paragraph, sidelights and a sternlight.

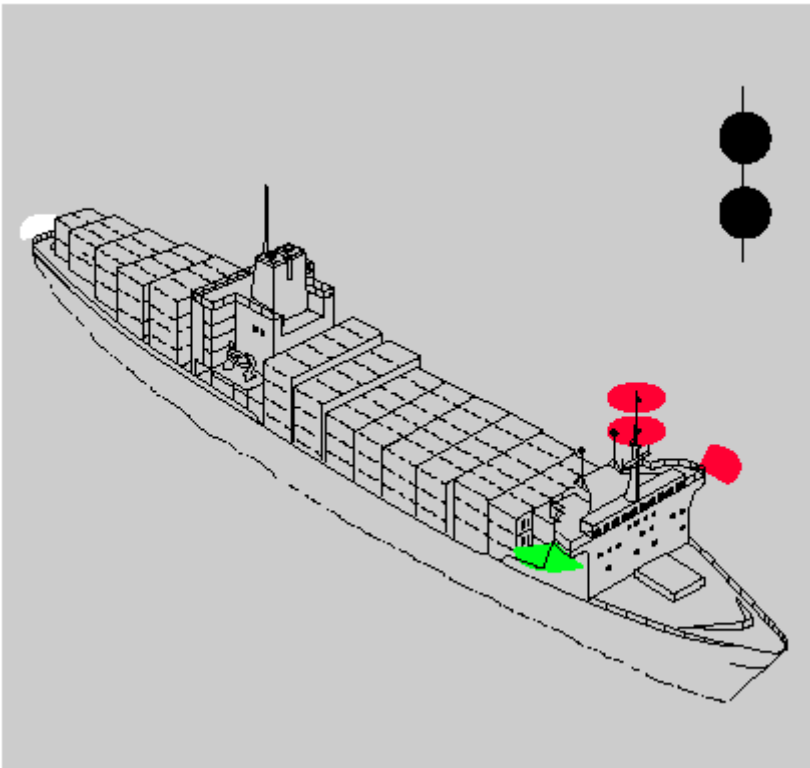

Vessel not under command—making way. Same for International.

# —INTERNATIONAL—

## Lights and Shapes

### RULE 27—CONTINUED

(b) A vessel restricted in her ability to maneuver, except a vessel engaged in mineclearance operations, shall exhibit:

(i) three all-round lights in a vertical line where they can best be seen. The highest and lowest of these lights shall be red and the middle light shall be white;

(ii) three shapes in a vertical line where they can best be seen. The highest and lowest of these shapes shall be balls and the middle one a diamond;

(iii) when making way through the water, a masthead light or lights, sidelights and a sternlight, in addition to the lights prescribed in subparagraph (i);

(iv) when at anchor, in addition to the lights or shapes prescribed in subparagraphs (i) and (ii), the light, lights or shape prescribed in Rule 30.

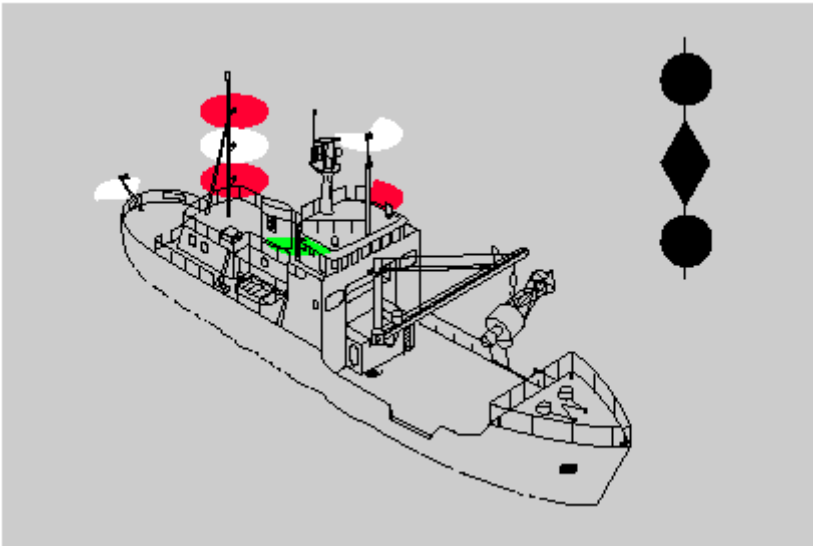

Vessel restricted in her ability to maneuver—making way; vessel less than 50 meters in length. Same for Inland.

# —INLAND—

## Lights and Shapes

### RULE 27—Continued

(b) A vessel restricted in her ability to maneuver, except a vessel engaged in mineclearance operations, shall exhibit:

- (i) three all-round lights in a vertical line where they can best be seen. The highest and lowest of these lights shall be red and the middle light shall be white;
- (ii) three shapes in a vertical line where they can best be seen. The highest and lowest of these shapes shall be balls and the middle one a diamond;
- (iii) when making way through the water, masthead lights, sidelights and a sternlight, in addition to the lights prescribed in subparagraph (b)(i); and
- (iv) when at anchor, in addition to the lights or shapes prescribed in subparagraphs (b)(i) and (ii), the light, lights or shapes prescribed in Rule 30.

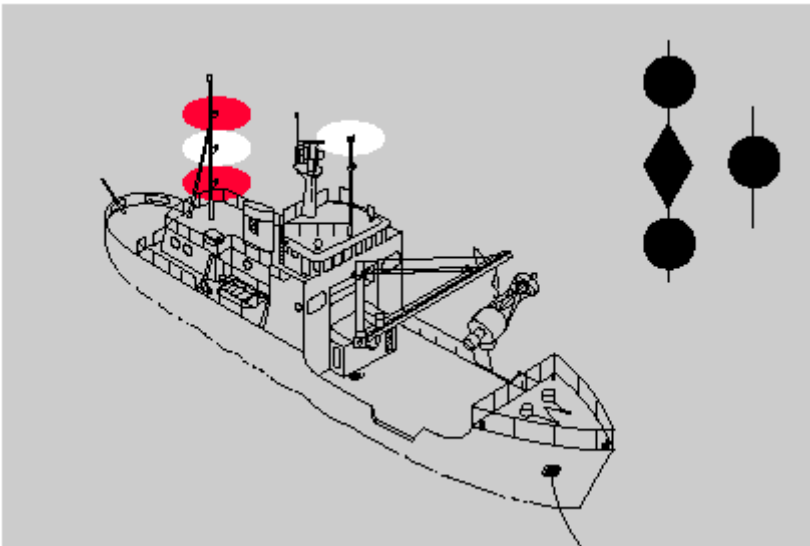

Vessel restricted in her ability to maneuver—at anchor; vessel less than 50 meters in length. Same for International.

# —INTERNATIONAL—

## Lights and Shapes

### RULE 27—CONTINUED

(c) A power-driven vessel engaged in a towing operation such as severely restricts the towing vessel and her tow in their ability to deviate from their course shall, in addition to the lights or shapes prescribed in Rule 24(a), exhibit the lights or shapes prescribed in subparagraphs (b)(i) and (ii) of this Rule.

# —INLAND—

## Lights and Shapes

### RULE 27—CONTINUED

(c) A vessel engaged in a towing operation which severely restricts the towing vessel and her tow in their ability to deviate from their course shall, in addition to the lights or shapes prescribed in subparagraphs (b)(i) and (ii) of this Rule, exhibit the lights or shape prescribed in Rule 24.

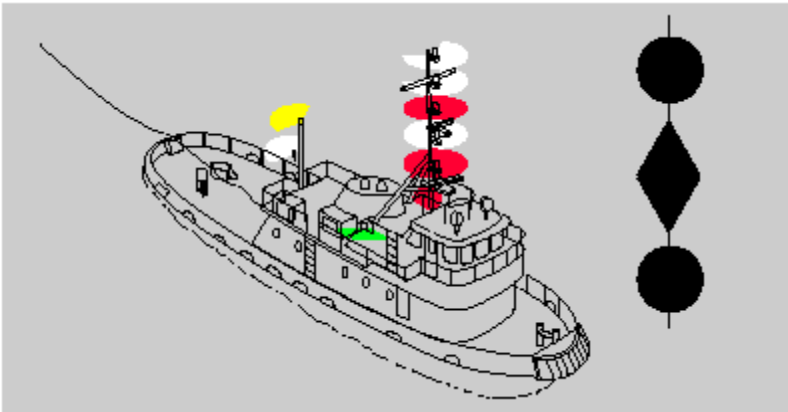

Vessel engaged in towing operation which severely restricts towing vessel and her tow in their ability to deviate from their course—length of tow does not exceed 200 meters; towing vessel less than 50 meters in length. Same for International.



# —INTERNATIONAL—

## Lights and Shapes

### RULE 27—CONTINUED

(d) A vessel engaged in dredging or underwater operations, when restricted in her ability to maneuver, shall exhibit the lights and shapes prescribed in subparagraphs (b)(i), (ii) and (iii) of this Rule and shall in addition, when an obstruction exists, exhibit:

- (i) two all-round red lights or two balls in a vertical line to indicate the side on which the obstruction exists;
- (ii) two all-round green lights or two diamonds in a vertical line to indicate the side on which another vessel may pass;
- (iii) when at anchor, the lights or shapes prescribed in this paragraph instead of the lights or shape prescribed in Rule 30.

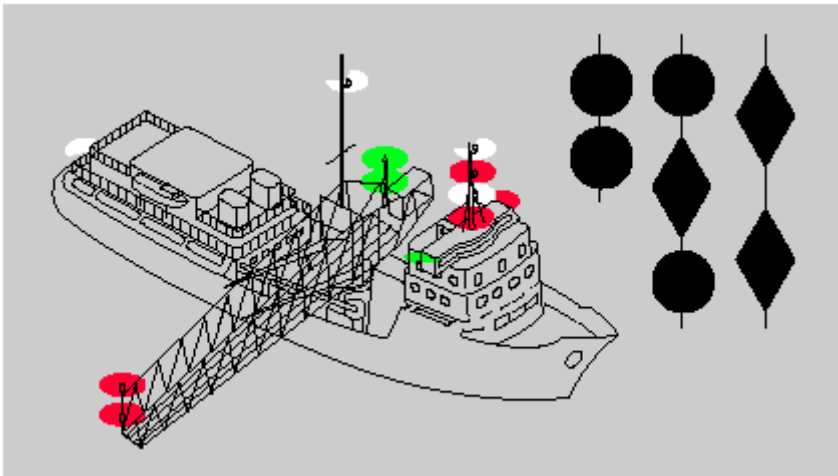

Vessel engaged in dredging or underwater operations when restricted in ability to maneuver—making way with an obstruction on the starboard side. Same for Inland.

# —INLAND—

## Lights and Shapes

### RULE 27—CONTINUED

(d) A vessel engaged in dredging or underwater operations, when restricted in her ability to maneuver, shall exhibit the lights and shapes prescribed in subparagraphs (b)(i), (ii), and (iii) of this Rule and shall in addition, when an obstruction exists, exhibit:

- (i) two all-round red lights or two balls in a vertical line to indicate the side on which the obstruction exists;
- (ii) two all-round green lights or two diamonds in a vertical line to indicate the side on which another vessel may pass; and
- (iii) when at anchor, the lights or shape prescribed by this paragraph, instead of the lights or shapes prescribed in Rule 30 for anchored vessels.

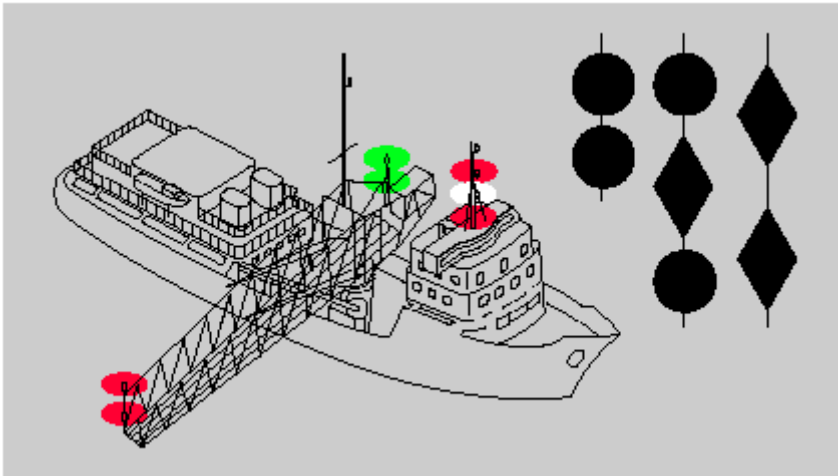

Vessel engaged in dredging or underwater operations when restricted in ability to maneuver—not making way with an obstruction on the starboard side. Same for International.

# —INTERNATIONAL—

## Lights and Shapes

### RULE 27—CONTINUED

(e) Whenever the size of a vessel engaged in diving operations makes it impracticable to exhibit all lights and shapes prescribed in paragraph (d) of this Rule, the following shall be exhibited:

(i) three all-round lights in a vertical line where they can best be seen. The highest and lowest of these lights shall be red and the middle light shall be white;

(ii) a rigid replica of the International Code flag “A” not less than 1 meter in height. Measures shall be taken to ensure its all-round visibility.

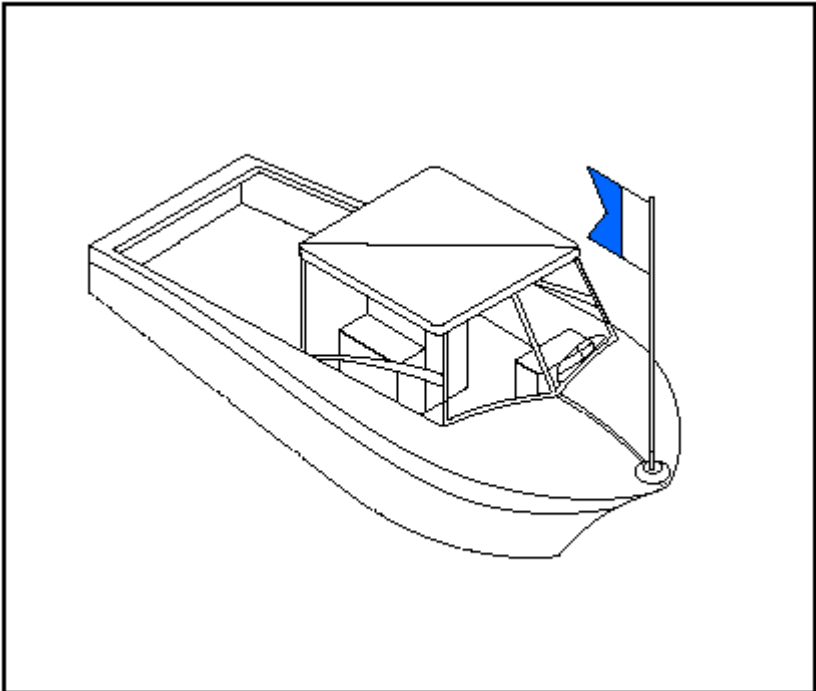

Small vessel engaged in diving operations. Same for Inland.

# —INLAND—

## Lights and Shapes

### RULE 27—CONTINUED

(e) Whenever the size of a vessel engaged in diving operations makes it impracticable to exhibit all lights and shapes prescribed in paragraph (d) of this Rule, the following shall instead be exhibited:

(i) Three all-round lights in a vertical line where they can best be seen. The highest and lowest of these lights shall be red and the middle light shall be white;

(ii) A rigid replica of the international Code flag "A" not less than 1 meter in height. Measures shall be taken to insure its all-round visibility.

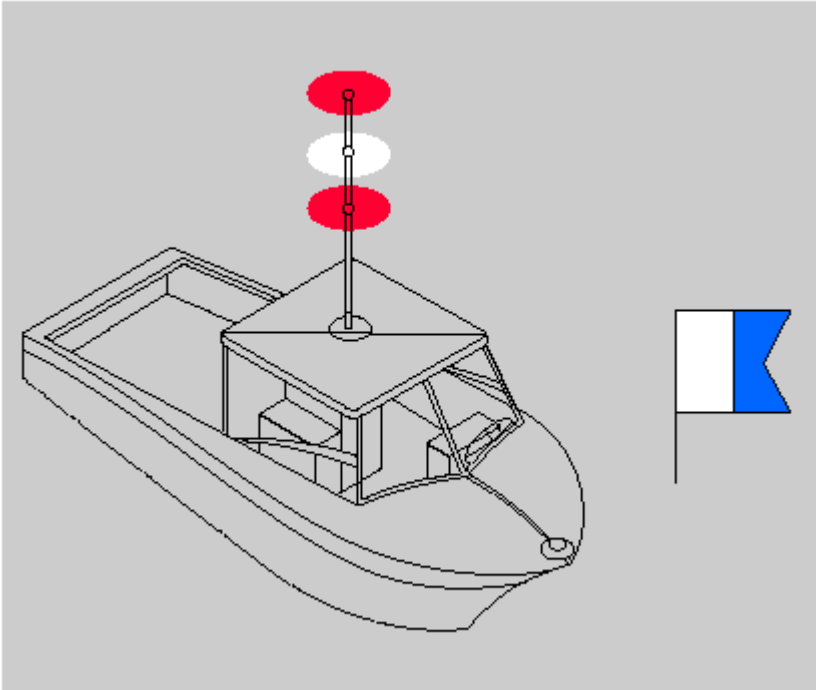

Small vessel engaged in diving operations. Same for International.

# —INTERNATIONAL—

## Lights and Shapes

### RULE 27—CONTINUED

(f) A vessel engaged in mineclearance operations shall, in addition to the lights prescribed for a power-driven vessel in Rule 23 or to the lights or shape prescribed for a vessel at anchor in Rule 30 as appropriate, exhibit three all-round green lights or three balls. One of these lights or shapes shall be exhibited near the foremast head and one at each end of the fore yard. These lights or shapes indicate that it is dangerous for another vessel to approach within 1000 meters of the mineclearance vessel.

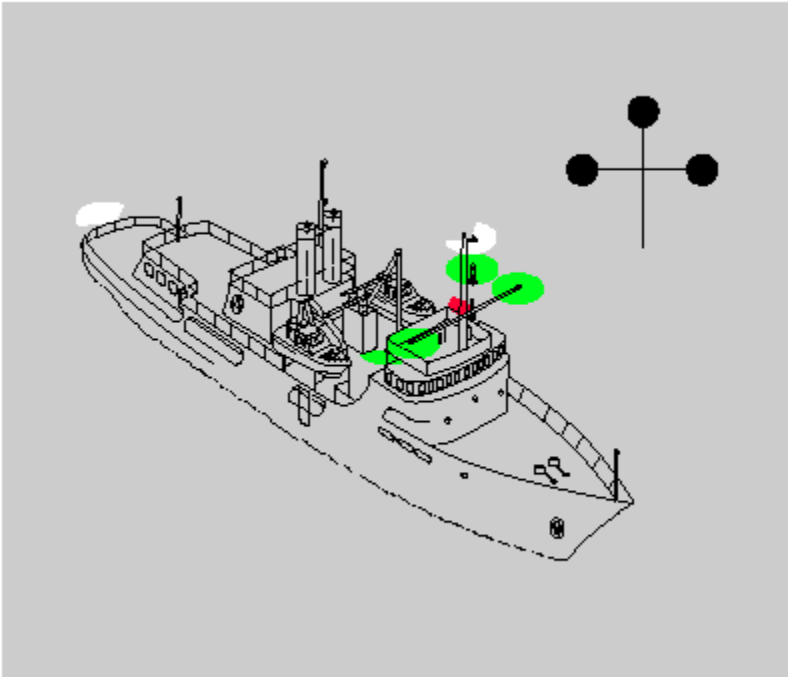

Vessel engaged in mineclearance operations—vessel less than 50 meters in length. Same for Inland.

# —INLAND—

## Lights and Shapes

### RULE 27—CONTINUED

(f) A vessel engaged in mineclearance operations shall, in addition to the lights prescribed for a power-driven vessel in Rule 23 or to the lights or shape prescribed for a vessel at anchor in Rule 30, as appropriate, exhibit three all-round green lights or three balls. One of these lights or shapes shall be exhibited near the foremast head and one at each end of the fore yard. These lights or shapes indicate that it is dangerous for another vessel to approach within 1000 meters of the mineclearance vessel.

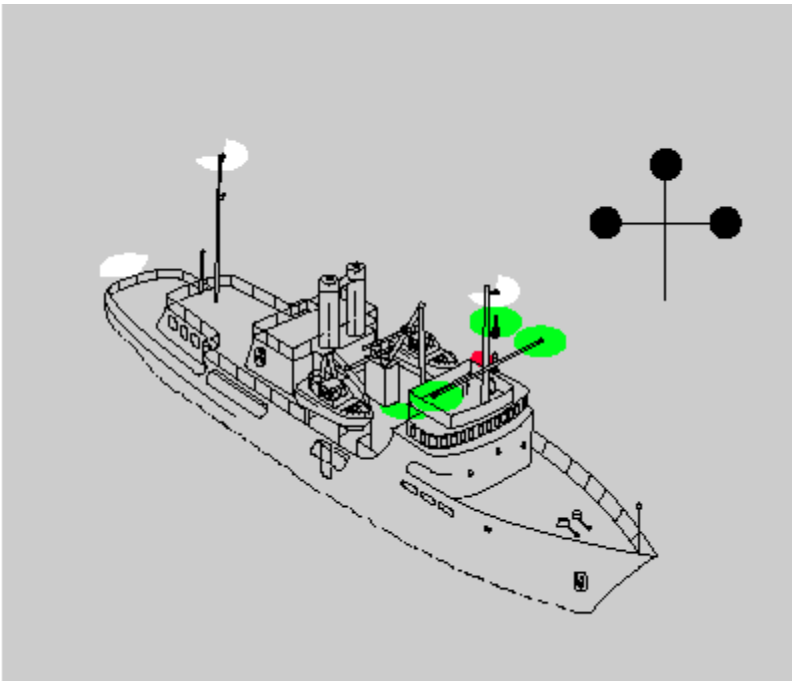

Vessel engaged in mineclearance operations.  
Same for International.

# —INTERNATIONAL—

## Lights and Shapes

### RULE 27—CONTINUED

(g) Vessels of less than 12 meters in length, except those engaged in diving operations, shall not be required to exhibit the lights and shapes prescribed in this Rule.

(h) The signals prescribed in this Rule are not signals of vessels in distress and requiring assistance. Such signals are contained in Annex IV to these Regulations.

# —INLAND—

## Lights and Shapes

### RULE 27—CONTINUED

(g) A vessel of less than 12 meters in length, except when engaged in diving operations, is not required to exhibit the lights or shapes prescribed in this Rule.

(h) The signals prescribed in this Rule are not signals of vessels in distress and requiring assistance. Such signals are contained in Annex IV to these Rules.



# —INTERNATIONAL—

## Lights and Shapes

### **RULE 28**

#### **Vessels Constrained by Their Draft**

A vessel constrained by her draft may, in addition to the lights prescribed for power-driven vessels in Rule 23, exhibit where they can best be seen three all-round red lights in a vertical line, or a cylinder. Vessel constrained by her draft.

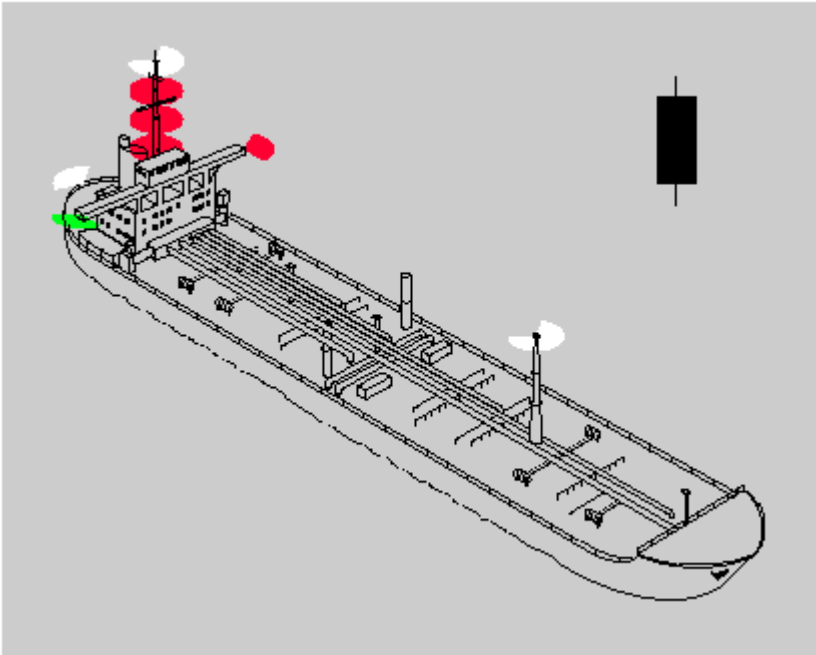

Vessel constrained by her draft.

—INLAND—  
Lights and Shapes

RULE 28

[Reserved]

# —INTERNATIONAL—

## Lights and Shapes

### **RULE 29** **Pilot Vessels**

- (a) A vessel engaged on pilotage duty shall exhibit:
- (i) at or near the masthead, two all-round lights in a vertical line, the upper being white and the lower red;
  - (ii) when underway, in addition, sidelights and a sternlight;
  - (iii) when at anchor, in addition to the lights prescribed in subparagraph (i), the light, lights or shape prescribed in Rule 30 for vessels at anchor.
- (b) A pilot vessel when not engaged on pilotage duty shall exhibit the lights or shapes prescribed for a similar vessel of her length.

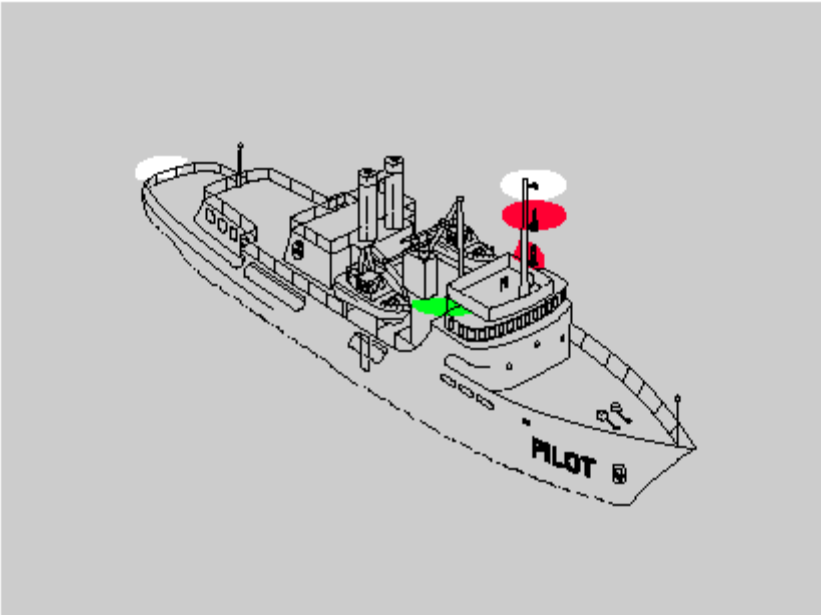

Vessel engaged on pilotage duty—underway. Same for Inland.

# —INLAND—

## Lights and Shapes

### **RULE 29** **Pilot Vessels**

- (a) A vessel engaged on pilotage duty shall exhibit:
- (b) at or near the masthead, two all-round lights in a vertical line, the upper being white and the lower red;
- (i) when underway, in addition, sidelights and a sternlight; and
- (ii) when at anchor, in addition to the lights prescribed in subparagraph (c) (i), the anchor light, lights, or shape prescribed in Rule 30 for anchored vessels.
- (c) (i), the anchor light, lights, or shape prescribed in Rule 30 for anchored vessels.
- (d) A pilot vessel when not engaged on pilotage duty shall exhibit the lights or shapes prescribed for a vessel of her length.

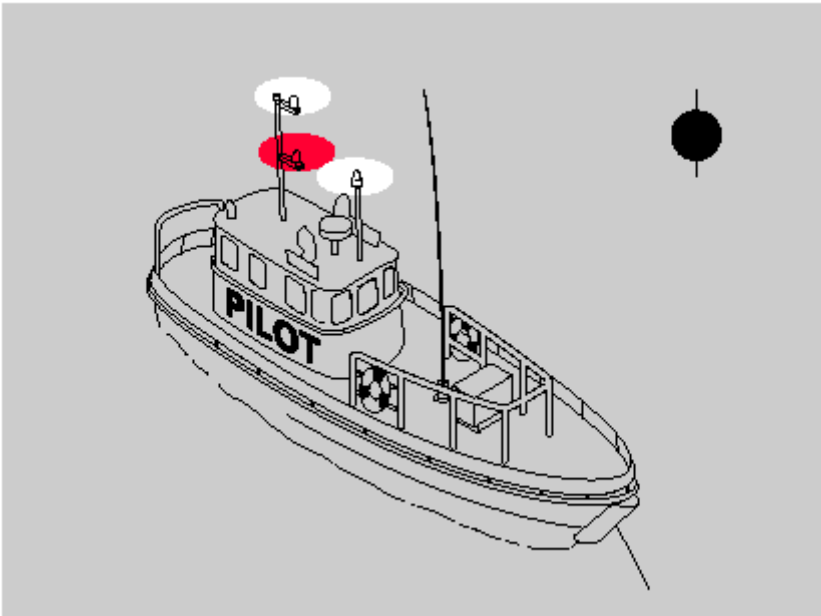

Vessel engaged on pilotage duty—at anchor; vessel of less than 50 meters in length. Same for International.

# —INTERNATIONAL—

## Lights and Shapes

### RULE 30

#### **Anchored Vessels and Vessels Aground**

(a) A vessel at anchor shall exhibit where it can best be seen:

(i) in the fore part, an all-round white light or one ball;

(ii) at or near the stern and at a lower level than the light prescribed in subparagraph (i), an all-round white light.

(b) A vessel of less than 50 meters in length may exhibit an all-round white light where it can best be seen instead of the lights prescribed in paragraph (a) of this Rule.

(c) A vessel at anchor may, and a vessel of 100 meters and more in length shall, also use the available working or equivalent lights to illuminate her decks.

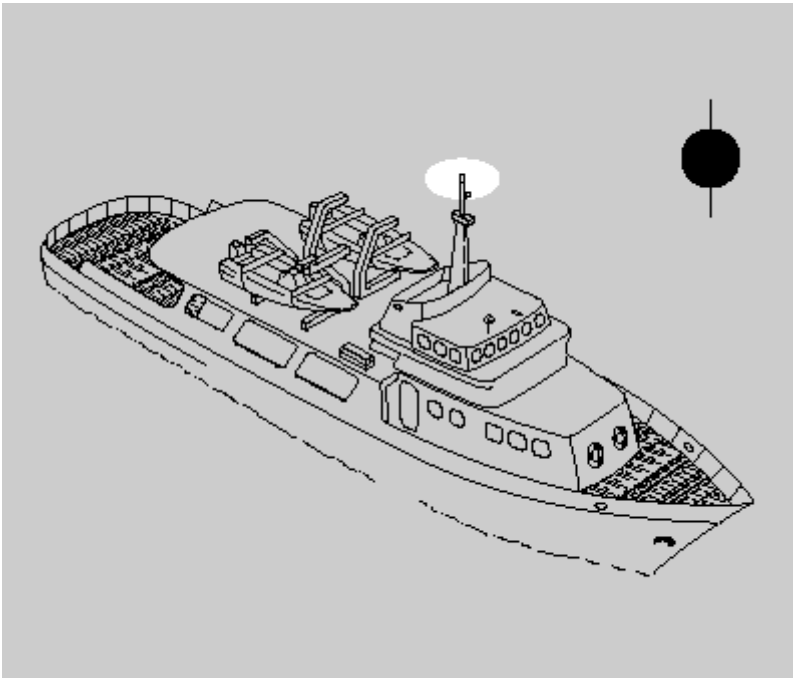

Vessel at anchor—less than 50 meters in length. Same for Inland.

# —INLAND—

## Lights and Shapes

### RULE 30

#### **Anchored Vessels and Vessels Aground**

- (a) A vessel at anchor shall exhibit where it can best be seen:
- (i) in the fore part, an all-round white light or one ball; and
  - (ii) at or near the stern and at a lower level than the light prescribed in subparagraph (i), an all-round white light.
- (b) A vessel of less than 50 meters in length may exhibit an all-round white light where it can best be seen instead of the lights prescribed in paragraph (a) of this Rule.
- (c) A vessel at anchor may, and a vessel of 100 meters or more in length shall, also use the available working or equivalent lights to illuminate her decks.

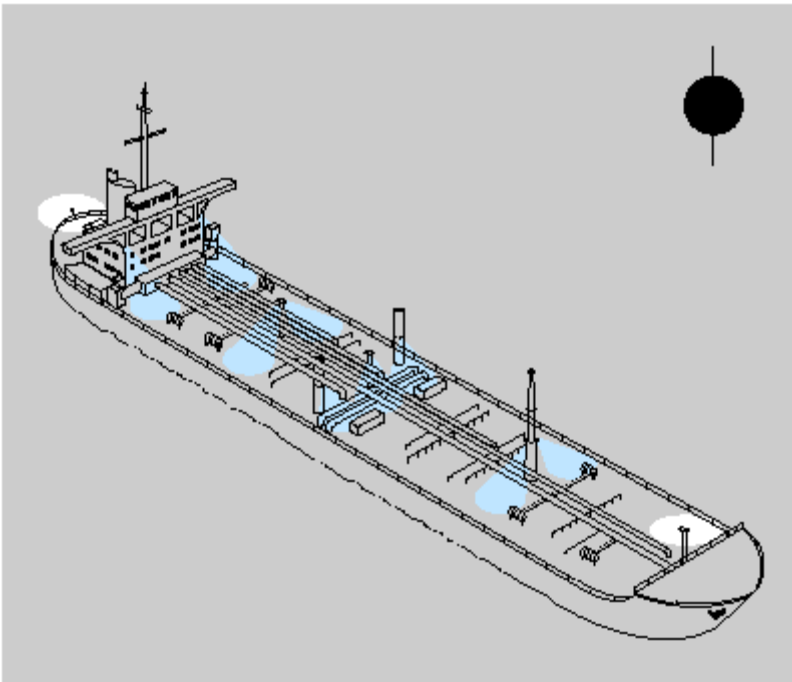

Vessel at anchor with deck illumination. Same for International.

# —INTERNATIONAL—

## Lights and Shapes

### RULE 30—CONTINUED

(d) A vessel aground shall exhibit the lights prescribed in paragraph (a) or (b) of this Rule and in addition, where they can best be seen:

- (i) two all-round red lights in a vertical line;
- (ii) three balls in a vertical line.

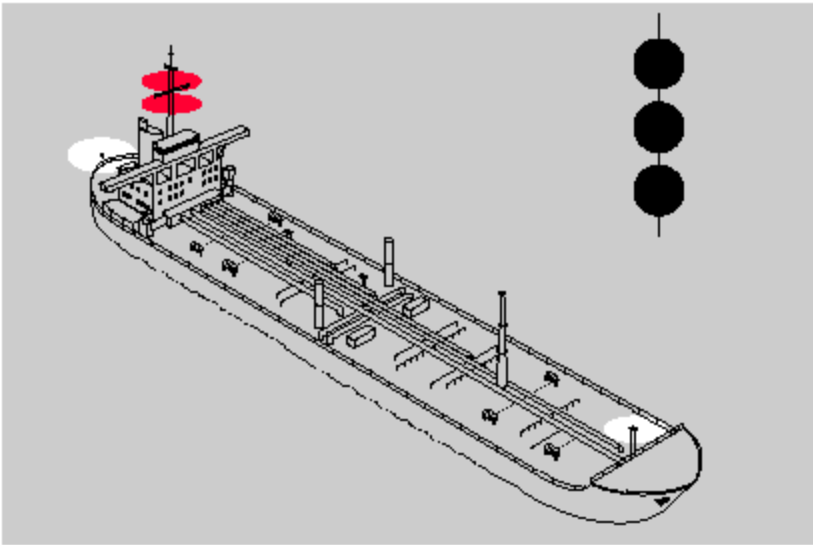

Vessel aground. Same for Inland.

# —INLAND—

## Lights and Shapes

### RULE 30—CONTINUED

- (d) A vessel aground shall exhibit the lights prescribed in paragraph (a) or (b) of this Rule and in addition, if practicable, where they can best be seen:
- (i) two all-round red lights in a vertical line; and
  - (ii) three balls in a vertical line.

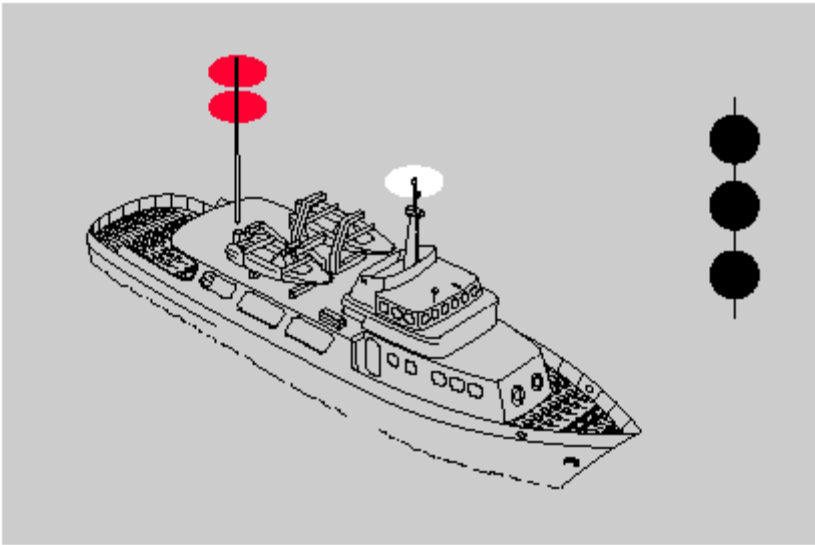

Vessel aground—less than 50 meters in length.  
Same for International.



# —INTERNATIONAL—

## Lights and Shapes

### RULE 30—CONTINUED

(e) A vessel of less than 7 meters in length, when at anchor, not in or near a narrow channel, fairway or anchorage, or where other vessels normally navigate, shall not be required to exhibit the lights or shape prescribed in paragraphs (a) and (b) of this Rule. (f) A vessel of less than 12 meters in length, when aground, shall not be required to exhibit the lights or shapes prescribed in subparagraphs (d)(i) and (ii) of this Rule.

# —INLAND—

## Lights and Shapes

### RULE 30—CONTINUED

(e) A vessel of less than 7 meters in length, when at anchor, not in or near a narrow channel, fairway, anchorage, or where other vessels normally navigate, shall not be required to exhibit the lights or shape prescribed in paragraphs (a) and (b) of this Rule.

(f) A vessel of less than 12 meters in length when aground shall not be required to exhibit the lights or shapes prescribed in subparagraphs (d)(i) and (ii) of this Rule.

(g) A vessel of less than 20 meters in length, when at anchor in a special anchorage area designated by the Secretary, shall not be required to exhibit the anchor lights and shapes required by this Rule.

# —INTERNATIONAL—

## Lights and Shapes

### **RULE 31**

#### **Seaplanes**

Where it is impracticable for a seaplane or a WIG craft to exhibit lights and shapes of the characteristics or in the positions prescribed in the Rules of this Part she shall exhibit lights and shapes as closely similar in characteristics and position as is possible.

# —INLAND—

## Lights and Shapes

### **RULE 31**

#### **Seaplanes**

Where it is impracticable for a seaplane to exhibit lights and shapes of the characteristics or in the positions prescribed in the Rules of this Part she shall exhibit lights and shapes as closely similar in characteristics and position as is possible.